

Operating Instructions

EBE 350 E

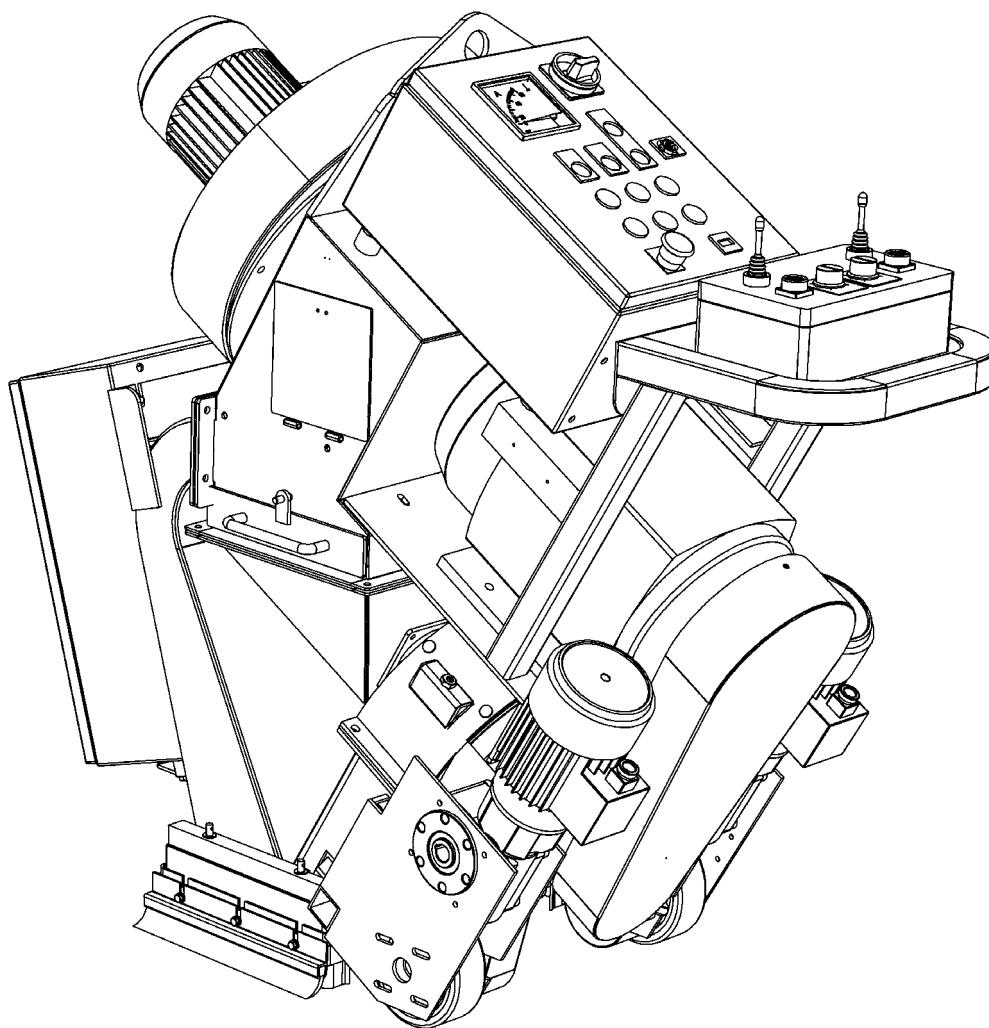

 **BLASTRAC**

MAN-EBE350E-EN

ISPC Blastrac/EBE
Utrechthaven 12
3433 PN Nieuwegein
THE NETHERLANDS
T +31(0)30 - 601 88 66
F +31(0)30 - 601 83 33
E info@surfacepreparation.nl
I www.surfacepreparation.com



Technical data	1
Safety instructions	2
General	3
Transport	4
Initial operation	5
Operation	6
Maintenance	7
Electrical & hydraulic systems	8
Fault diagnosis	9
Spare parts	10

Contents Chapter 1



1.1 Rating

1.2 Unit specifications

1.3 Operative range and correct usage

1.4 Stand-by power supply (generator)

1.5 Machine type designation

1.6 Advice for operators of blast cleaning machines

Technical data

1.1 Rating

Unit / designation : **ISPC Blastrac/EBE** blast cleaning machine

Machine type : EBE 350 E

Manufacturer : **ISPC Blastrac/EBE**
Utrechthaven 12
NL-3433PN Nieuwegein
THE NETHERLANDS

1.2 Unit specifications

Dimensions:

	Machine EBE 350 E	
Length	1350	mm
Width	650	mm
Height	1100	mm
Weight	375	kg

Connected loads (electrical system):

The indicated input current values correspond to the nominal current values of the motors working under full load. These values are not achieved under normal operating conditions.

	Power consumption	Input current
EBE 350 E Blast wheel drive	11.0 / 13.0 kW	max. 20 A
Fan motor	1.5 / 1.8 kW	max. 3.5 A
Drive motors	0.37 kW	max. 1.78 A

Electrical connection required : 400-480 V, 50/60 Hz, 32 A

Technical data

	Rated speed	Freq	Enclosure
Drive of blast wheel	2920 / 3525 min ⁻¹	50 / 60 Hz	IP 55
Fan motor	2840 / 3415 min ⁻¹	50 / 60 Hz	IP 55
Drive wheel motors	1370 min ⁻¹	50 / 60 Hz	IP 55



- Blast wheel size : 225 mm Ø
- Working width : 350 mm
- Drive speed : 0 - 15 m/min
- Blast cleaning output on steel : up to 50 m²/h
- Dust hose connection : 130 mm Ø
- Recommended abrasive : Shot 390-460 / SG18-16
- Abrasive consumption : 0,1 - 0,5 kg/m²
- Recommended filter unit : EBE 350 DAAM

1.3 Operative range and correct usage

The EBE 350 E is exclusively designed to clean dry, frost-free horizontal surfaces. The machine may not be used for other purposes. The manufacturer will not be liable for damage resulting from such incorrect usage. In these cases the user assumes all risks.



Technical data

1.4 Stand-by power supply (generator)

1



If the EBE 350 E blast cleaning machine is operated using a generator, this generator must be operated in accordance with the current VDE directives (this applies to the protective earth conductor in particular) in order to ensure that all safety devices are functioning and to eliminate possible damage to electrical components.

1.5 Machine type designation

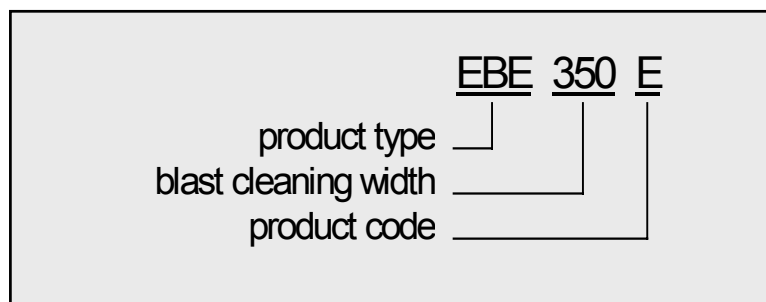

1.6 Advise for operators of blast cleaning machines



In accordance with the accident prevention regulations for blast cleaning work (VBG 48) the operator must provide operating instructions for blast cleaning work in a form and language that is understandable.

The blast cleaning machine Operating Instructions are only part of these operating instructions. Please consult the current accident prevention regulations for the precise content.

Contents Chapter 2

2.0 Warnings and symbols

2.1 Organisational measures

2.2 Personnel selection and qualification

2.3 Safety precautions applicable to different operating conditions

2.4 Special work within the scope of use of the equipment and maintenance activities as well as repairs during operation

2.5 Definition of the **Safety off position**

2.6 Particular dangerous aspects of the equipment

2.7 Electrical engineering regulations

Safety instructions

2.0 Warnings and symbols

The following denominations and symbols are used in the Operating Instructions to highlight areas of particular importance:

2



Symbol of operational safety.
 In these Operating Instructions this symbol will be shown next to all safety precautions that are to be taken in order to ensure prevention to life and injury. Follow these instructions and take special care in these circumstances. In addition to these instructions, the general safety precautions and accident prevention guidelines are also to be followed.



Particular details regarding the economical use of the equipment.



Information, instructions and restrictions with regard to possible risks to persons or to extensive material damages.

Warning against dangerous voltages.



Indications relating to protective devices in electrical appliances.



2

Indications where consultation with the manufacturer is required.



Instructions relating to periodical checks.

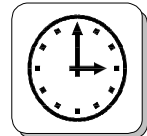

Reference to important instructions contained in the Operating Instructions.



2.1 Organisational measures

The **Operating Instructions** are to be kept **near the location where the machine** is located and must be **within reach at all times!**



In addition to the Operating Instructions general and legal regulations regarding accident prevention and environmental protection must be complied with and indicated!

Such duties may for example relate to the handling of hazardous substances or to the provision and wearing of personal protection equipment as well as compliance with traffic regulations.

Safety instructions

The Operating Instructions must be **supplemented** by **instructions** including the duty to **supervise** and **report** relating to **particular working practices**, for example work organisation, work procedures and personnel allocation.

2 Personnel entrusted with working with the machine must have read the **Operating Instructions** before starting work, in particular the **Safety Instructions** chapter. To read these instructions during work is too late. This particularly applies to incidental activities such as setting up the equipment, carrying out maintenance work or training staff to work with the machine.

From time to time the working practices of the staff are to be checked regarding awareness of **safety and hazards**.

Personnel must tie back long hair and not wear loose clothing or jewellery including rings. There is a risk of injury through getting stuck or being drawn into moving machinery.



Use **personnel protection equipment** if necessary or required by regulations! Take notice of **all** safety and hazard notices on the machine!

All **safety and hazard notices** at or on the machine must be kept complete and **legible**!

If **safety-critical changes** occur to the machine or its working method, the machine must be **shut down immediately**! The cause of the fault must be established immediately!



Changes, add-ons or conversions to the machine which might impair safety must not be undertaken **without the manufacturer's permission**!

This applies in particular to the fitting and adjustment of safety devices as well as to welding on load-bearing parts.

Spare parts must comply with the technical requirements specified by the manufacturer. This is always guaranteed if original spare parts are used.

Intervals for recurring **checks and inspections** specified in these Operating Instructions must be complied with!

Safety instructions

To perform maintenance work correctly it is imperative to be equipped with the proper tools for the task in question.

The **location** and the operation of **fire extinguishers** must be made known on each building site!

Take note of the facilities for reporting and fighting fires!

2

2.2 Personnel selection and qualification

Fundamental duties :

Work on the machine may only be undertaken by **reliable personnel**.

Only trained personnel may be deployed. **Note the statutory minimum age!** Specify clearly the responsibilities of personnel for operation, setting up, servicing and maintenance work!

Make sure that only **authorised** personnel operate or work on the machine!

Define responsibilities of the machine operator also regarding to **traffic safety regulations** and empower him to decline instructions from third parties which are not complying with the safety requirements!

Personnel being trained or made acquainted with the equipment may only be deployed on the machine **under constant supervision of an experienced person!**

Safety instructions

2.3 Safety precautions applicable to different operating conditions

Ban any method of working that **impairs safety!**

2



Only operate the machine when all **safety devices** and related **safety equipment**, e.g. detachable **safety devices**, emergency stops and suction devices are present and **operational!**

Check the machine visually for any **damage** and **defects** at least once a day!

In the event of **operational malfunctions** the machine must be **shut down immediately** and secured, and the fault must be rectified!



Secure the **work area** around the machine in **public areas** providing a **safety distance** of at least 2 m from the machine.

Before switching on the machine make sure that no-one can be endangered when the machine starts up!

Do not switch off or remove the exhaust and ventilation devices when the machine is running!



All persons in the proximity of the machine must wear ear protectors, safety glasses with lateral protection as well as safety shoes. The operator is obliged to wear close-fitting protective clothing.



Use only extension cable for extending the main cable that are sized and marked in accordance with the overall power consumption of the machine and the valid VDE guidelines.

Safety instructions

2.4 Special work within the scope of use of the equipment and maintenance activities as well as repairs during operation

Mechanical servicing work:

Put the machine in the **Safety off position** as described in chapter 2.5 for any servicing work on the machine in order to prevent the machine from being **switched on** accidentally.

Please follow any special **safety instructions** in the various chapters on servicing the machine.

See chapter 7.1 - 7.9.

Adjustment, servicing and inspection work and time limits specified in these Operating Instructions as well as any information on the replacement of parts and equipment must be **undertaken and/or complied with!**

These activities may only be undertaken by **qualified personnel**.

Do not use any **aggressive** cleaning materials!
Use lint-free **cleaning cloths!**

Always tighten any screw connections that are undone during servicing and maintenance work!

If **safety devices** need to be **dismantled** during setting up, servicing and repairs, these **safety devices** must be **reinstalled** and inspected immediately after completion of the servicing and repair work.

Make sure that process materials and replaced parts are disposed of safely and in an environmentally-friendly manner!

Electrical servicing work:

Make sure that electrical components used for replacement purposes comply with the original parts and are correctly adjusted if necessary.

For safety notes see 2.7 Electrical engineering regulations.

Safety instructions

2.5 Definition of the Safety off position

Definition:

The machine is in a safe condition when it cannot generate any hazard.

Putting the equipment in the Safety off position means:

- Close the valve.**
- Switch off the blast machine.**
- Switch off the dust collector.**
- Wait for standstill of all drives.**
- Pull out mains plug.**

Safety instructions

2.6 Particular dangerous aspects of the equipment

Any machine, if it is **not used according the regulations**, may be **hazardous** for operating, setting-up and service personnel. The **operating authority** is responsible for **compliance with the safety regulations** during operation and maintenance of **safety devices** supplied with the machine as well as the provision of appropriate additional safety devices!



2

	<p>1. Blast housing outlet</p> <p>Danger of injury!</p> <p>Abrasive leaves housing with high speed! Moving parts!</p> <p>Lift and cant the machine only when it is in Safety off position.</p> <p>It is not allowed to stay within the working radius of the machine!</p>
--	--

	<p>2. Wheels</p> <p>Danger of injury!</p> <p>Moving parts!</p> <p>It is not allowed to stay within the working radius of the machine!</p>
--	--

Safety instructions

2.7 Electrical engineering regulations

2



Work on **electrical** equipment or operating materials may only be undertaken by a **skilled electrician** or by **trained** persons under the **guidance** and **supervision** of a **skilled electrician** as well as in accordance with the **electrical engineering regulations**.



Use only extension cable for extending the main cable that are sized and marked in accordance with the overall power consumption of the machine and the valid VDE guidelines.



The electrical equipment for the plant must **inspected regularly**. Please note in particular the **specified recurring inspections** according **EN60204-1**. Defects such as **loose** connections or **scorched** cables must be rectified **immediately**. **Call a skilled electrician or our Customer Services**.

A **second** person must be deployed who can pull out the plug in an emergency if work on **live** parts is necessary. The work area must be sealed off using a red and white **safety chain** and a danger sign. Use a tool that is **insulated against voltages**.

Only start work once you are familiar with the **electrical engineering regulations** that apply to your area.

Only use voltage seekers that **comply with the regulations** when troubleshooting. From time to time check voltage seekers to ensure that they are operationally efficient.

Contents Chapter 3

- 3.1 Introduction
- 3.2 Operating instructions
- 3.3 Connections
- 3.4 Care and maintenance
- 3.5 Scope of supply
- 3.6 Description
- 3.7 Control box
- 3.8 Operating elements
- 3.9 Blast wheel
- 3.10 Separator and hopper
- 3.11 Drive system
- 3.12 Abrasive sealing
- 3.13 Air suction and filter system
- 3.14 Abrasive media

General

3.1 Introduction

ISPC Blastrac/EBE wants to thank you for your decision to employ the blast cleaning machine EBE 350 E for the treatment of horizontal surfaces.

The machine has a closed abrasive circuit with dust separation. This comprehensively avoids damaging the environment and endangering the operating staff.

The EBE 350 E is designed to remove coatings, non-skid, epoxy, bitumen and asphalt on different types of horizontal surfaces.

3.2 Operating instructions

This manual has been written to support the operating personnel on learning the functioning of the machine and to guarantee optimum operation and maintenance.



Therefore it is important that all persons operating and maintaining the machine read this manual carefully and understand it fully.

The supplied machine has been manufactured for being employed in the user's country. All descriptions and notes have been formulated in the language of the user's country or in English in accordance with the statutory regulations, or shown as pictograms. If the customer deploys personnel with little knowledge of the language of the user's country, appropriate instruction and training must be provided.



Before using the machine personnel must be familiar with how to operate the machine, with all important components, with the method of working and with its dimensions.



ISPC Blastrac/EBE offers a course on the use of the machine in order to make the operating and maintenance personnel familiar with all elements of the blast cleaning machine.

General

Initial commissioning of the machine must be carried out very carefully. The machine operator must fully understand the sequence of commissioning of the individual parts and their functioning.



All persons in the proximity of the machine in operation must wear ear protectors, safety glasses with lateral protection and safety shoes. The machine operator must wear close-fitting protective clothing.

3

3.3 Connections

Machine	Voltage	Connection type
EBE 350 E	400-480V 50/60Hz	32A

3.4 Care and maintenance

Special attendance and regular maintenance of the machine and its parts are imperative for functioning and safety.

In order to prevent unnecessary downtimes it is recommended to keep original spare and wear parts on stock as listed in the maintenance box.

A list of contents of the maintenance box is provided in Chapter 10 to enable the above-mentioned work to be carried out quickly.



WARNING: BLASTRAC EBE machines build for the American market are especially build to run on 440-480V 60Hz. If the machines are operating on a Voltage or Hz lower than 440V and 60Hz, this will damage the electric components.



General

3.5 Scope of supply

Scope of supply of the machine:

- Blast cleaning machine (EBE 350 E)
- Dust hose
- Operating instructions (2 x)
- Maintenance box (option)
- Magnetic broom (option)

3.6 Description

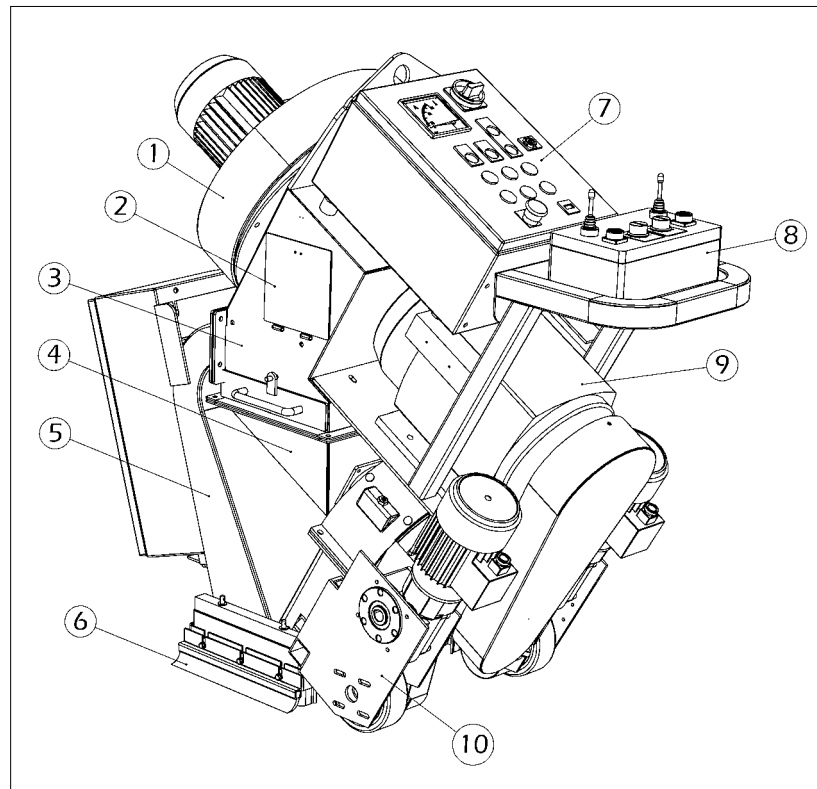

Fig. 3.1

- | | | | |
|---|----------------|----|---|
| 1 | Fan unit | 6 | Blast head, rubber sealing, brush sealing |
| 2 | Separator door | 7 | Control box |
| 3 | Separator | 8 | Drive control box |
| 4 | Hopper | 9 | Blast wheel motor |
| 5 | Blast body | 10 | Drive wheel |

The **ISPC Blastrac/EBE** blast-cleaning machine EBE 350 E is a downwards-blasting machine with a closed abrasive circuit designed for the pre-treatment of horizontal surfaces. The bouncing impact of metallic abrasive onto the surface to be treated thoroughly removes surface contaminants, coats of paint, sealants and thin coatings. Like many revolutionary inventions the blast wheel method is based on a simple principle: after mechanical pre-acceleration the abrasive is thrown onto the surface at high speed by the blast wheel. Once the abrasive has impacted on the surface it rebounds into a recovery duct. The recovery duct deflects the abrasive into an air current separator. Here dust and other contaminants are removed from the abrasive so that only abrasive containing a very small amount of dust is fed into the abrasive storage hopper for re-use by the blast wheel.

A suitable filter unit must be connected to the machine in order to separate the dust from the abrasive.

A specially designed dust collection system ensures dust-free operation of the machine and clean air at the workspace.

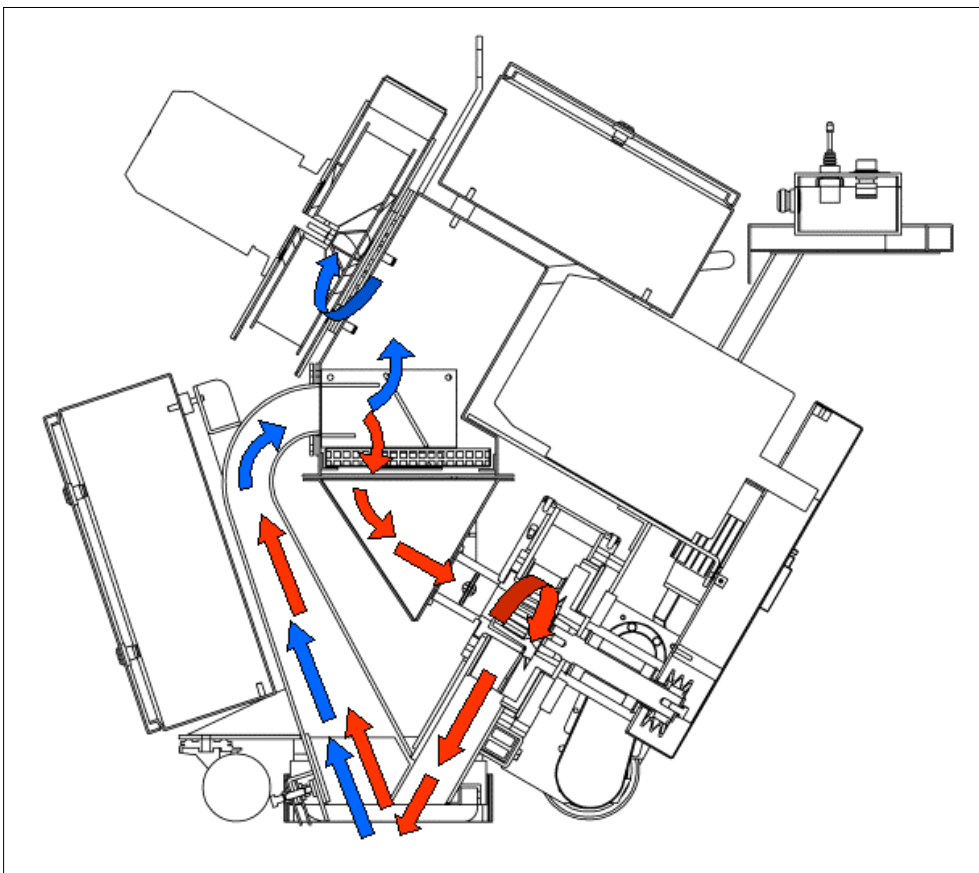

Fig. 3.2

General

3.7 Control box

The control box is equipped with all control elements and instruments for monitoring and controlling the blast cleaning machine.

3

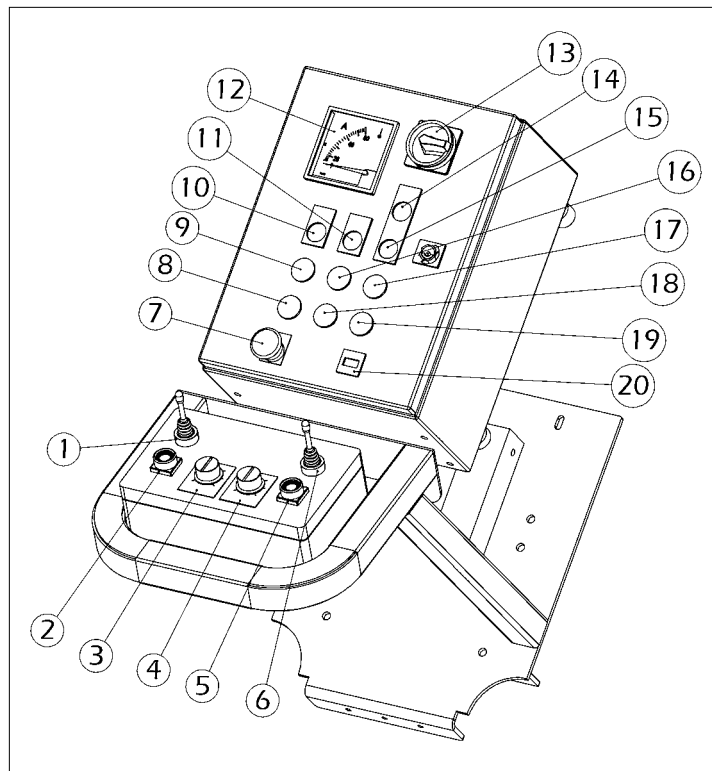

Fig. 3.3

- | | |
|------------------------------|---------------------------------|
| 1 Drive wheel joystick left | 11 Control lamp "Fan" |
| 2 Left motor "STOP" | 12 Ammeter |
| 3 Drive speed control | 13 Main switch |
| 4 Tracking control | 14 Control lamp voltage |
| 5 Right motor "STOP" | 15 Control lamp "Main blast" |
| 6 Drive wheel joystick right | 16 Push button "Fan ON" |
| 7 Emergency shutdown switch | 17 Push button "Main blast ON" |
| 8 Push button "Drive OFF" | 18 Push button "Fan OFF" |
| 9 Push button "Drive ON" | 19 Push button "Main blast OFF" |
| 10 Control lamp "Drive" | 20 Hour counter |

Main switch

The main switch is located on the main box at the front of the machine. It has to be switched on before operation.

General

Emergency shutdown switch

The emergency shutdown is a red mushroom-shaped press switch. Pressing this switch immediately interrupts power supply to all machine components. Releasing this switch makes the control lamp "Power" light up

Push buttons "Drive ON/OFF"

Pressing the push button "Drive ON" switches the drive control on. The machine can now move forward and backward by using the drive wheel joysticks. Pressing the push button "Control OFF" switches the drive control off.

Push buttons "Fan ON/OFF"

Before pressing this button make sure that the filter unit is switched on and working. Pressing the push button "Fan ON" switches the machine fan on. An airflow is generated from the blast head towards the filter unit.. Pressing the push button "Fan OFF" switches the machine fan off.

Push buttons "Main blast ON/OFF"

Before pressing this button make sure that the shot valve is closed. Pressing the push button "Main blast ON" switches the blast wheel motor on. Pressing the push button "Main blast OFF" cuts of the motor power supply immediately. Pay attention that the blast wheel will continue rotating for some time after pressing the OFF button!

Drive wheel joysticks left/right

Operating these joysticks together makes the machine run forward ot backward. Releasing one of the joysticks makes the machine turn to the left or the right.

Drive speed control

Although this indication does not allow direct reading of the actual speed, it shows comparing numbers allowing the operator to set the appropriate speed.

General

Ammeter

The ammeter shows the load consumption of the blast wheel motor. When switching on the motor the current value is high (starting current peak) and falls, after having reached the idle speed, to approximately 8 A. With full load it may rise to a maximum of 20 A.

Hour counter

The hour counter on the main box shows the sum of the actual working hours performed by the blast wheel.

3.8 Operating elements

The shot valve

Between the abrasive storage hopper and the blast housing there is a valve in order to control the abrasive flow towards the blast wheel. Any change in the opening of the valve causes the amount of abrasive fed to the blast wheel to change. The change in the abrasive fed can be read from the ammeter. The valve is hand-operated and can be adjusted so that any quantity of abrasive can be fed to the blast wheel. Optimum blast cleaning power is reached when the ammeter indicates 20 A. It is not permitted to blast with a higher current value.

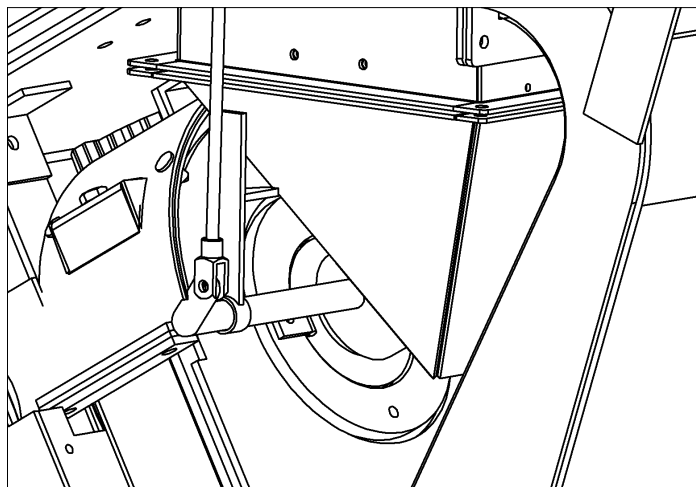

Fig. 3.4

The shot valve handle

This handle is located at the right side of the hopper and regulates the shot valve to control the flow of abrasive towards the blast wheel. When the handle is pulled upwards, the shot valve is opened and abrasive is allowed to travel towards the blast wheel in a progressive, controlled manner.

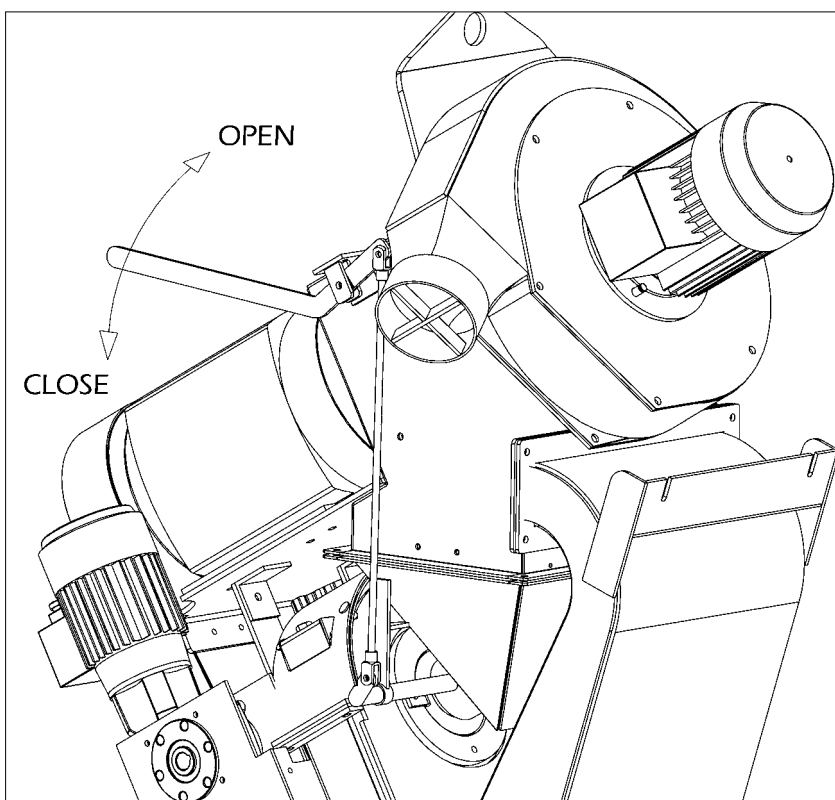

Fig. 3.5 Shot valve OPEN / CLOSE

General

3.9 Blast wheel

The heart of the blast-cleaning machine is a blast wheel that throws the abrasive onto the surface to be cleaned by using centrifugal force. The blast wheel is placed in a protective housing lined with replaceable wear parts. The blast wheel is driven by a electric motor.

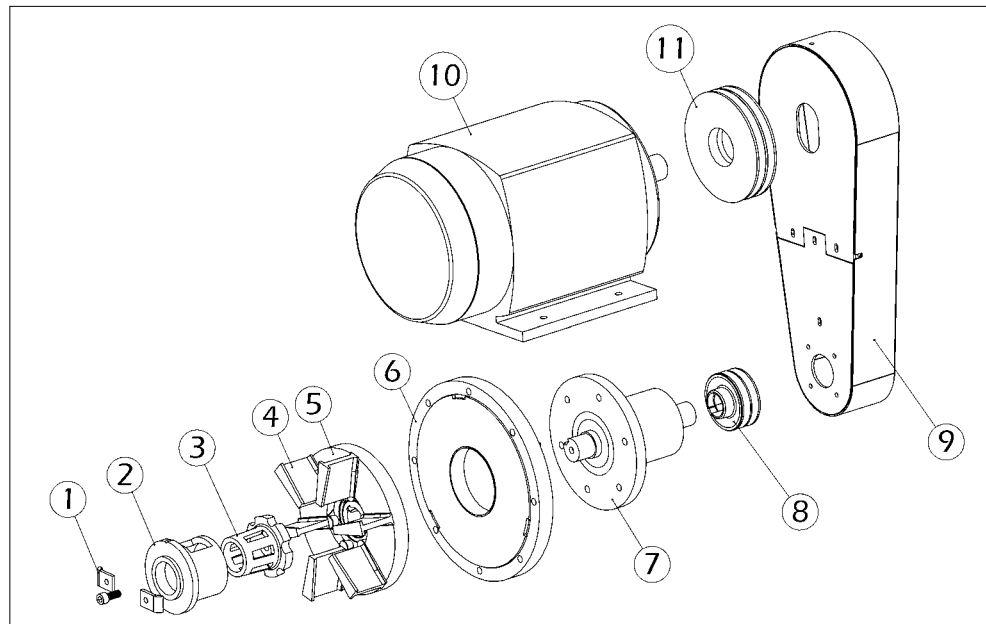

Fig. 3.6

Around the centre of the blast wheel there is the impeller feeding dosed quantities of abrasive onto the blades of the turning blast wheel. On top of this is the control cage (with 1 notch) which, once it is carefully set, regulates the flow of abrasive.

- 1 Control cage clamp
- 2 Control cage
- 3 Impeller
- 4 Blades (set of 6)
- 5 Blast wheel
- 6 Motor adaption plate
- 7 Bearing unit
- 8 Pulley
- 9 Belt guard
- 10 Blast wheel motor
- 11 Pulley

3

3.10 Separator and hopper

The abrasive separator is mounted to the end of the recovery duct. It separates the abrasive from contaminants and feeds the cleaned abrasive back to the abrasive storage hopper.

A wire mesh is fitted to prevent any coarse contaminants from getting into the blast wheel. In order to clean the wire mesh drawer the drawer can be removed from the side.

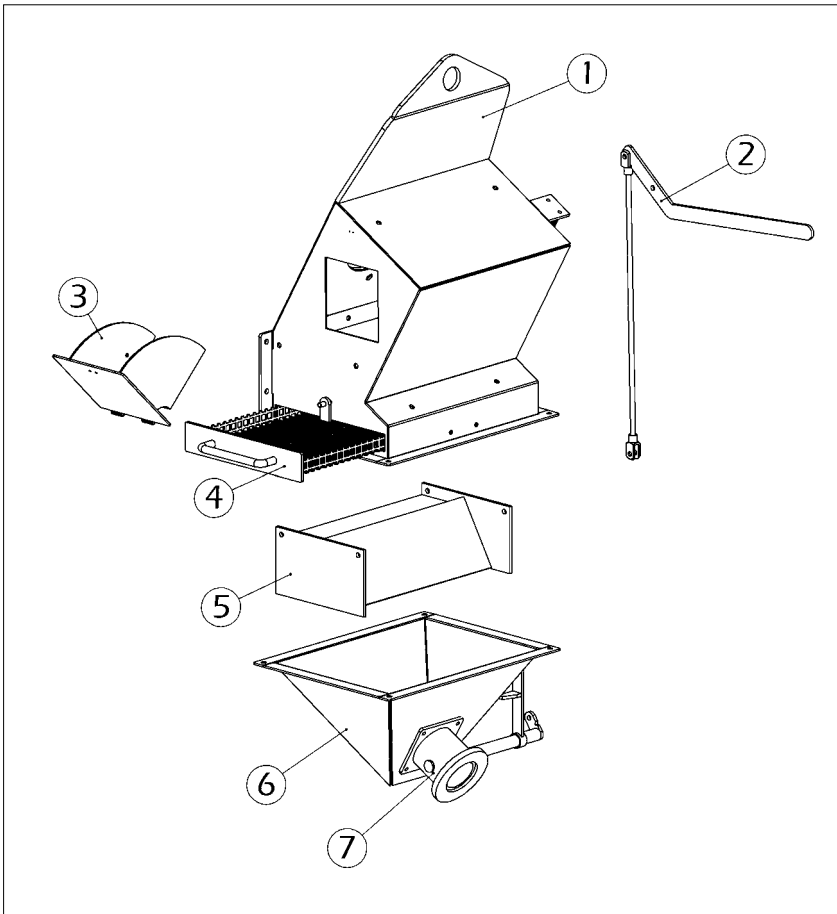

Fig. 3.7

- 1 Separator
- 2 Shot valve handle
- 3 Separator door
- 4 Separator tray
- 5 Baffle plates
- 6 Abrasive storage hopper
- 7 Shot valve

General**3.11 Drive system**

The drive system is an independent electric system contained within the main box at the front of the blast housing cabinet. There is an *On/Off* switch on the electrical panel to operate this drive control system.

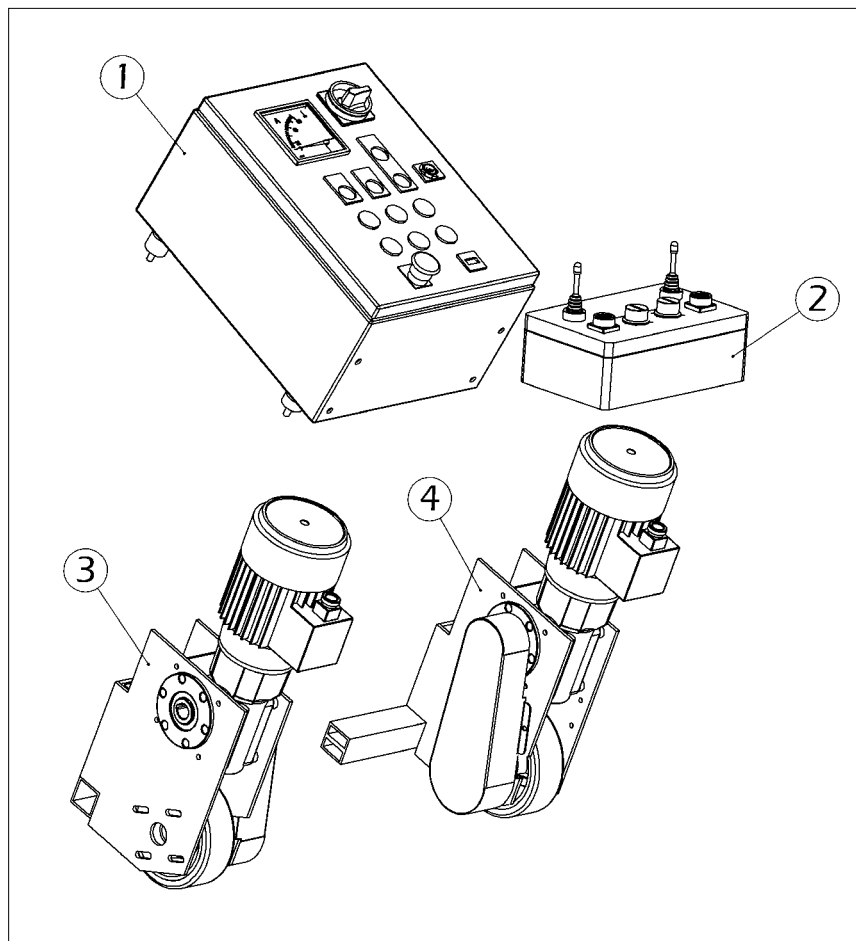

Fig. 3.8

- 1 Control panel
- 2 Drive control box
- 3 Drive wheel left
- 4 Drive wheel right

3.12 Abrasive sealing

The front seal system comprises of three polyurethane seals to ensure that good fit is maintained between the side seals and the work surface at the bottom. The seals are located in a seal box at the front of the blast opening of the cabinet and are clamped into place by bolts and plates.

To obtain access to front seal system:

1. Make sure that the power unit is stopped.
2. Allow the machine to tip backwards until the rear of the machine rests on the surface; this will lift the front of the machine and gives access to the front seal locating box.
3. Unscrew the bolts at the front of the seal locating box, this releases the clamp system holding the seals. Pull worn seals out of the locating box.
4. Fit new seals, each interspaced with a steel strip. Tighten the bolts again.
5. Start up and commence work.

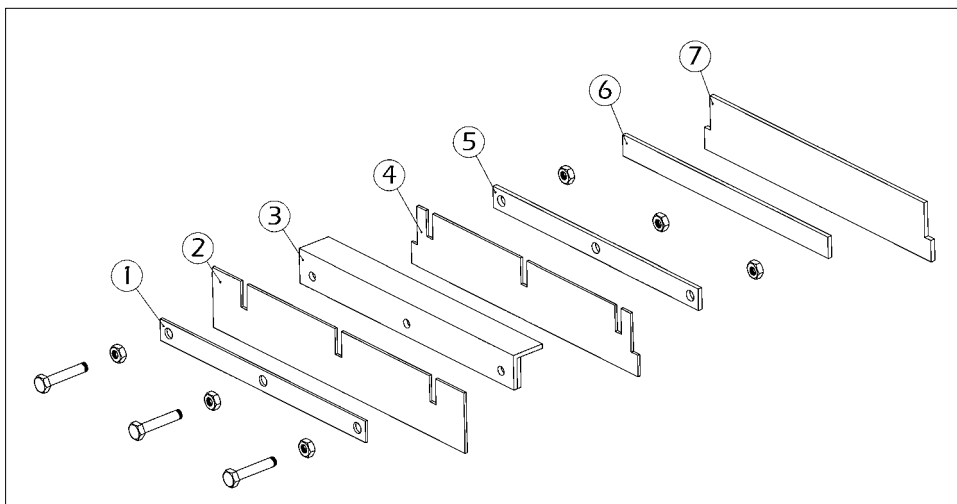

Fig. 3.9

- | | |
|------------------------------|------------------------|
| 1 Front locating plate outer | 5 Locating plate inner |
| 2 Front skirt outer | 6 Fixing plate |
| 3 Front seal angle (machine) | 7 Front skirt inner |
| 4 Front skirt intermediate | |

General

Side seal system:

The side skirts and brushes are fixed to each side seal box with a plate and four screws. To replace them: unscrew the screws and remove the side skirts and brush and replace them if necessary.

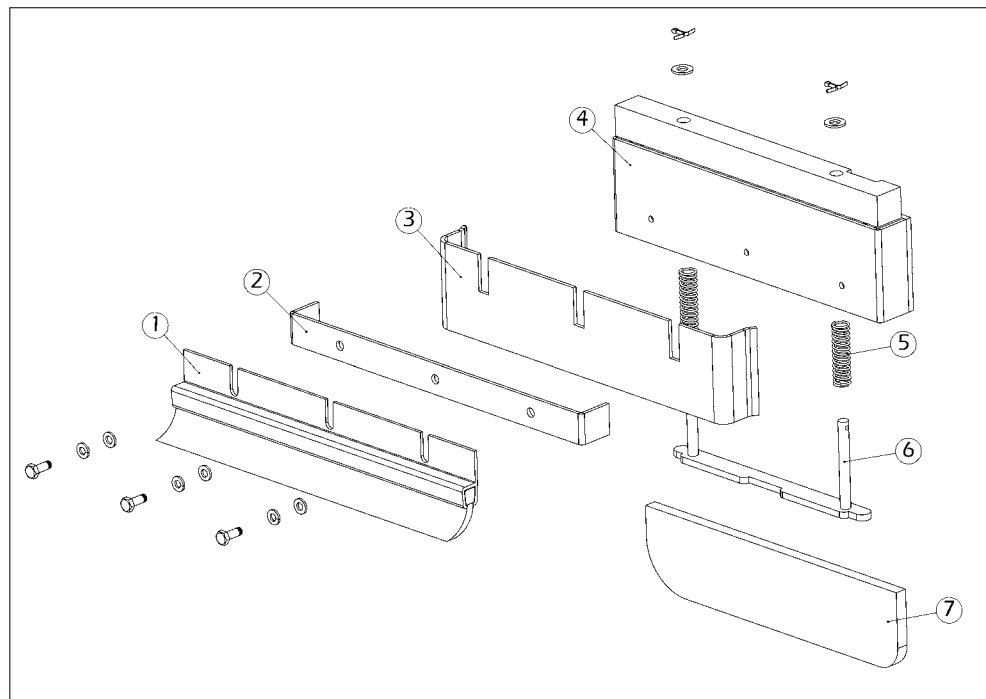

Fig. 3.10

- 1 Side brush
- 2 Side skirt fixing plate
- 3 Side skirt
- 4 Seal box
- 5 Side seal spring
- 6 Side seal spring plate
- 7 Side seal

Method of installing the side seals:

It is necessary to lift one side of the machine at a time to enable the seals to be put in place at the bottom. This is achieved as follows:

1. Check that power to the machine is off.
2. Lift the front of the machine and slide the side seals into the seal boxes at the bottom of the housing.
3. Lower the machine and check that both axles of the side seal spring plates have come out at the top of the seal boxes, to be sure that the side seals are positioned correctly.

3

Rear seal system:

The rear seal system comprises of one back brush and a back brush skirt, which are located inside the rear seal box. They are clamped in place by locking screws.

To replace the rear seals:

- 1 Tip the machine backwards on the floor.
- 2 Unscrew the locking screws and pull out the worn rear seals.
- 3 Fit a new back brush and back brush skirt into the rear seal box and tighten the locking screws.
- 4 Lower the machine, fit the side seals and check that both axes of the side seal spring plates have come out at the top of the seal boxes, to be sure that the side seals are positioned correctly.
- 5 Put the machine back on its wheels and commence work.

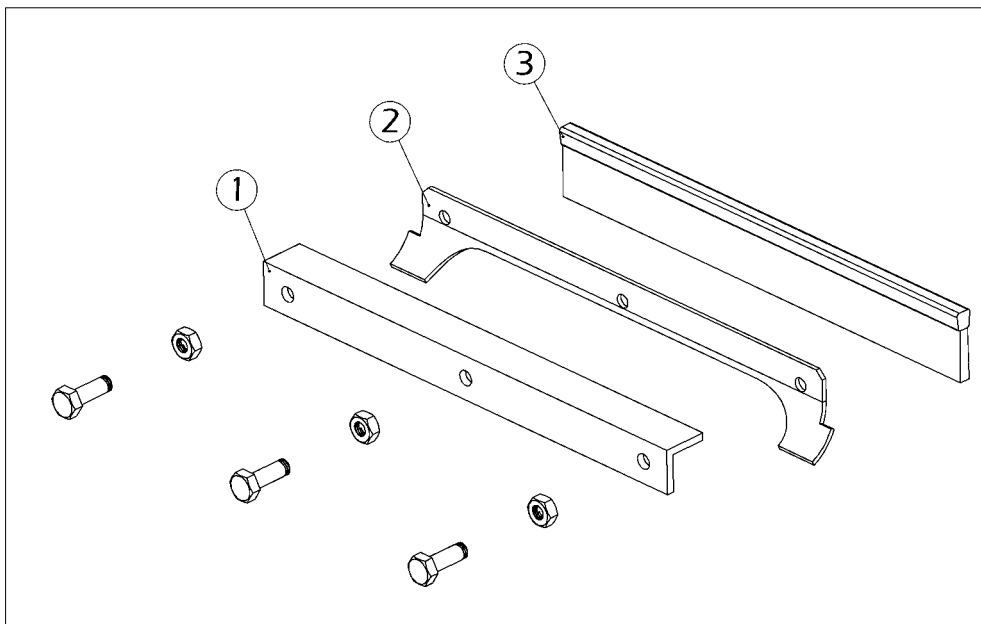

Fig. 3.11

- 1 Rear seal angle (machine)
- 2 Back brush skirt
- 3 Back brush

General

3.13 Air suction and filter system

The air streaming through the complete system, created by exhaust fans (one on the dust arrester, one on the machine), has the following functions:

- Cooling of the blast wheels
- Cooling of the abrasive
- Transport of the abrasive
- Transport of dust through the system
- Separation of dust from the re-useable abrasive
- Transport of dust to the filter unit

Machine fan:

Motor output : 1.5 / 1.8 kW

Air throughput : 1200 m³/h

Dust hose:

Length : 20 m

Diameter : 130 mm

All connection points must be sealed carefully and the dust hose must be fixed with hose clamps!

The filter housing must be sealed properly and all sealings must be in good condition!

If dust leaves the filter unit instead of clean air, this is a sign that the filter cartridges are either damaged or not fixed correctly inside the filter chamber.

The air streams through the machine as follows:

- Air is sucked in at the rear seal and carries along abrasive and dust.

- ❑ The air stream flows through the rebound plenum and carries along abrasive and dust. In doing so the air stream cools the abrasive and the housing walls.

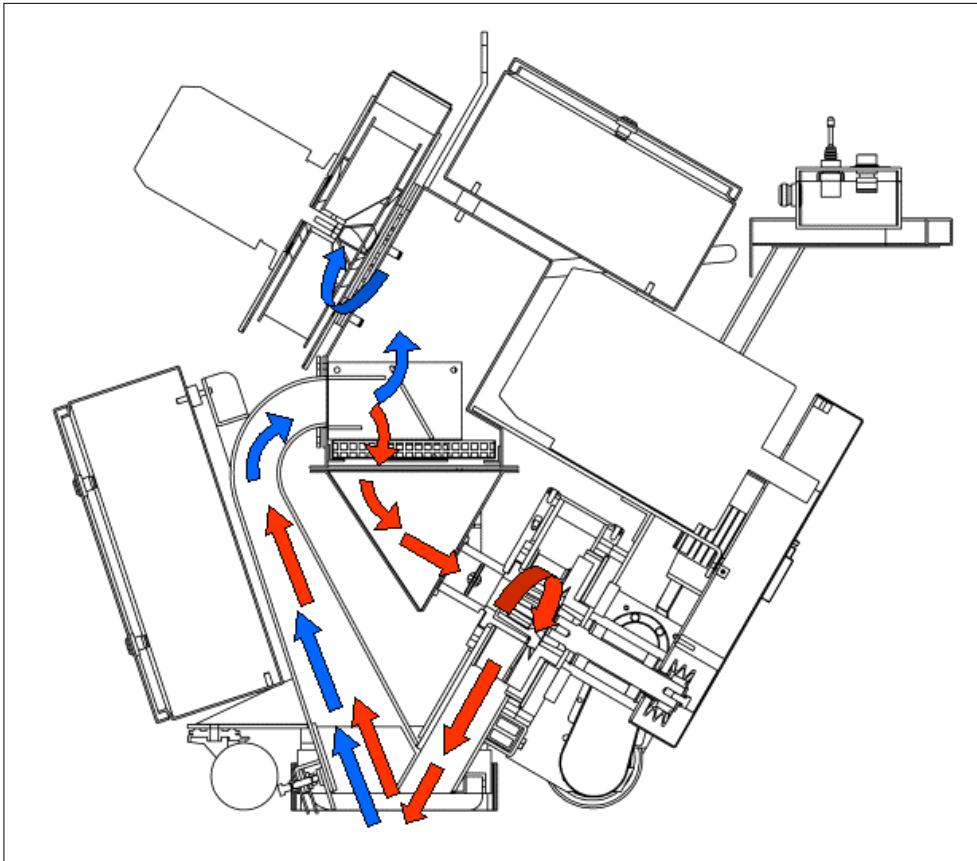

Fig. 3.12

- ❑ The air enters the separator, separates the fine dust from the abrasive and transports the dust to the outlet opening. The separator door must be closed airtight in order to grant an optimum performance of the separator.
- ❑ The air stream then flows through the approx. 20 m (up to max. 90 m) long flexible dust hose taking dust and fine particles with it.
- ❑ The air stream now enters the filter chamber of the filter unit where the dust and the fine particles are separated from the air. The cleaned air is then fed into the environment again.

General**3.14 Abrasive media**

In order to operate the **ISPC Blastrac/EBE** machine EBE 350 E you need hardened (max. 45 Rockwell), spherical abrasive. The machine EBE 350 E has been especially designed to be operated with **ISPC Blastrac/EBE** abrasive.

The **ISPC Blastrac/EBE** abrasive is of very high quality and owns the rebounding ability required for the efficient use of model EBE 350 E. The selection of the abrasive is very important since this is the material to carry out the surface treatment.

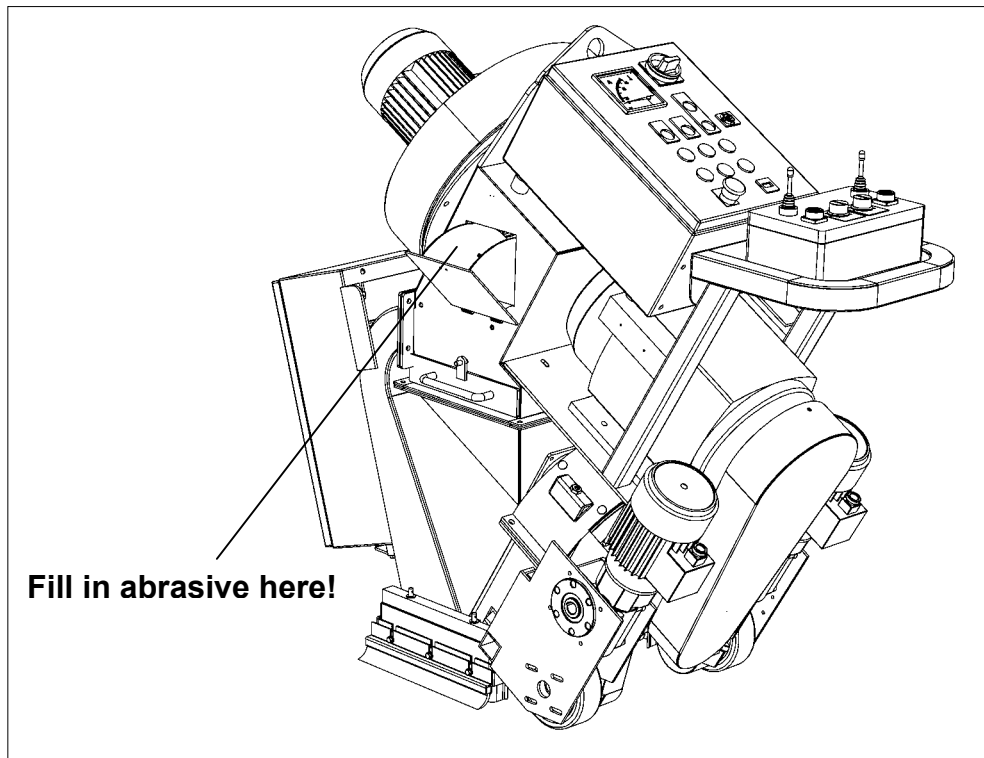

Fig. 3.13

Selection of abrasive

Abrasive shot S390 – S460:

Standard abrasive, suitable for about 50-60 % of all applications. Creates a medium profile on concrete.

Applications:

- removes laitance from new concrete
- roughening of smooth concrete or natural stone
- removes coatings with a thickness of 1-3 mm and cleaning of steel surfaces

3**Abrasive shot S390 - S460 with SG18-16:**

For removal of coatings from steel surfaces mix approx. 75% S390 - S460 shot with 25% SG18 or SG16 grit. The type of grit is depending on the profile requirements.

Applications:

- removes polyurethane coatings
- removes adhesive remnants
- removes rubber deposits
- penetrates coatings hard to remove
- also suitable to be used on steel
- removes non-skid coatings from navy vessels

**Warning: never use abrasive harder than 45 Rockwell !
Otherwise the wear in the machine would increase disproportionately.**



General

The effectiveness of the EBE 350 E depends on the rebound effect which ensures that the abrasive can be re-used.

Please take into account that the use of incorrect abrasive increases wear.

Our service engineers have the experience to select the appropriate abrasive for the individual cases of application.

Please consult our local **ISPC Blastrac/EBE** customer service department if you have any questions about the selection of the best abrasive for your blast cleaning work.

3



Contents Chapter 4

4.1 General notes

4.2 Transport

4.3 Operation conditions

4.4 Operation

4.5 Unit specifications

A grey right-angled triangle pointing to the right, with the number "4" inside it.

4

Transport

4.1 General notes



Before the machine is used for the first time, **ISPC Blastrac/EBE** authorised dealers offer a course to familiarise maintenance and operating personnel with all elements of the machine. We are not liable for damage caused by incorrect use of the machine by personnel not trained by **ISPC Blastrac/EBE**.

4.2 Transport

When transporting the machine proceed in such a manner that damage due to the effects of the use of force or incorrect loading and unloading is avoided.

Remove the abrasive from the machine before it is transported. The machine may only be lifted by using the suspension eyelets. The weight and dimensions of the machine are shown in Chapter 1 "Technical data".

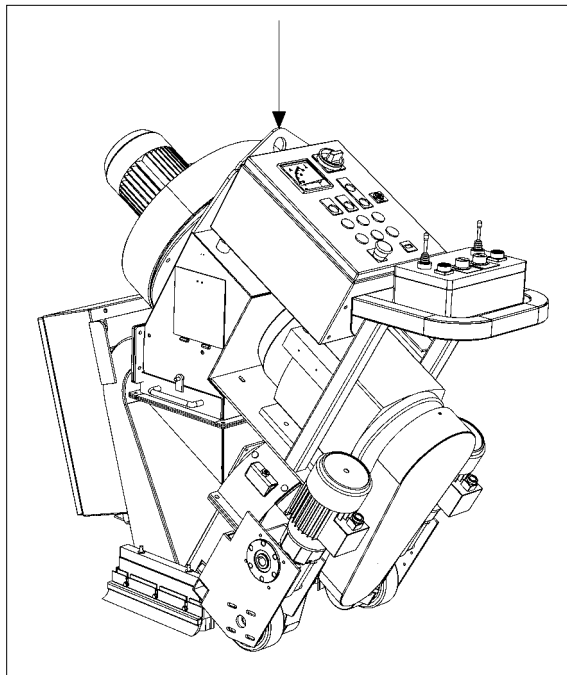

Fig. 4.1

The machine is to be transported after being separated into:

- Machine
- Filter unit
- General accessories

4.3 Operation conditions

Check the surface to be treated for loose parts (stones, screws, etc.) and fluids (water, oil, etc.). The surface must be swept and cleaned if necessary. Make sure that the machine can travel over all inequalities on the surface. Small inequalities like weld seams or floor joints are no barriers for the machine.

4.4 Operation

The machine is operated in accordance with the instructions given in Chapter 5 "Initial operation".

Whenever the machine is not used for blast cleaning, the abrasive valve must always be closed!



Please note that the illustrations are simplified.

4.5 Unit specifications

The main dimensions and unit specifications of the machine when assembled are shown in Chapter 1 "Technical data".



Contents Chapter 5

5.1 Preparations for initial operation

5.2 Initial operation

Initial operation

5.1 Preparations for initial operation

Before switching on make sure that all existing protective housings are mounted and that the filter unit is connected correctly.



All persons in the proximity of the machine must wear ear protectors, safety glasses with lateral protection as well as safety shoes. The operator is obliged to wear close-fitting protective clothing.



Handle all plugs, cables, hoses and operating devices with care. Avoid any contact with live wires.

Works on the electrical system must only be carried out by qualified specialists.

5 Check the surface to be treated for loose parts (stones, screws, etc.). The surface must be swept if necessary. Make sure that the machine can travel over all inequalities on the surface. Small inequalities like weld seams or floor joints are no barriers for the machine.



Regular inspection is important in order to avoid downtimes. Carry out the following checks before any start-up:

- Check whether all machine parts are assembled safely and correctly.
- Check all screws and other fasteners for tight seat.
- Check the abrasive storage hopper, the feed spout and the blast wheel parts for foreign bodies and remove them.
- Check the blast wheel blades, impeller, control cage, liners and fastening screws for damages and wear.
Wear will take place in the form of grooves worn into blades along path taken by abrasive from center of blastwheel outwards. Wear grooves are acceptable until 75% of blade thickness has been worn away. When this point is reached, replace all blades as a set.
- Check the front, side and rear seal systems and brush seals for wear.

Initial operation

- ☑ Check the tightness of the hose connections and the condition of the hose to the filter.
- ☑ Make sure the dust container of the filter unit is empty.
- ☑ Check the separator parts for wear and defects. Remove foreign bodies and dust deposits in order to prevent the separator from being blocked.
- ☑ Check the electrical connections for dirt and foreign body deposits.
- ☑ Check the electrical motors for dirt and other contaminants.
- ☑ Check the level of abrasive in the storage hopper. Refill if necessary.

Before start-up the operating personnel must be familiar with the safety regulations given in this manual.



5

- ☑ Check the main power cable and the dust hose for damage. Replace or repair all damaged parts before starting the machine.
- ☑ Connect the blast cleaning machine and the filter unit with the dust hose. Use hose clamps at the connections.
- ☑ Connect the supply cable of the blast cleaning machine with filter unit. Connect the electric cable of the filter unit with the site supply (400-480 V, 50/60 Hz, 32 A).
- ☑ Install the side seals in the side seal boxes (see Chapter 3.12).

Initial operation

- ☑ Fill approx. 25 kg of the selected abrasive (see Chapter 3.14) into the abrasive storage hopper of the blast cleaning machine. The shot valve must be closed whilst doing this.

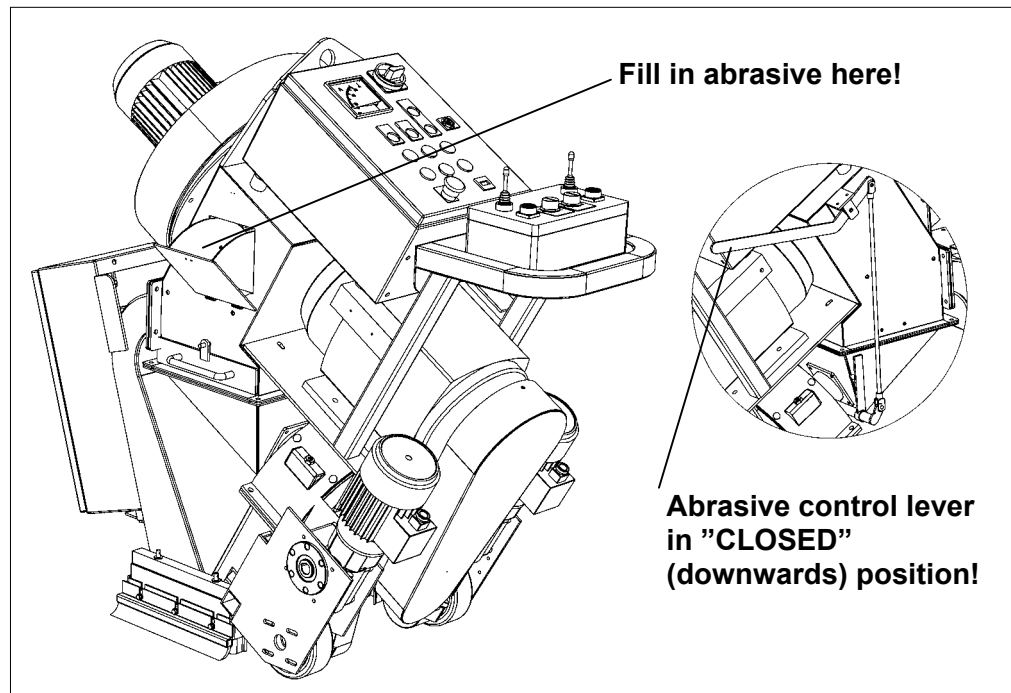

Fig. 5.1

- ☑ Check that the filter dust container has been emptied.

5.2 Initial operation



All persons in the proximity of the machine must wear ear protectors, safety glasses with lateral protection as well as safety shoes. The operator is obliged to wear close-fitting protective clothing.

The start of the blast cleaning machine and the filter unit is effected in the following sequence:

1 Switching on the filter unit

- ☐ Main switch of the filter unit "ON".

Initial operation

- Compressor "ON".
- Fan "ON".
- Pulsator "ON".
- Check the turning direction of the filter and compressor motor. The correct turning direction is indicated by the arrow on the belt guard.

2 Initial operation of the blast cleaning machine

- Check that the shot valve is closed (abrasive shot valve handle downwards, see fig. 5.1).
- Check that the emergency shutdown switch is not actuated.
- Switch the main switch of the machine to "ON". The control lamp "Power" on the control box lights up.
- Press the push button "Drive ON".
- Press the push button "Fan ON".
- Press the push button "Main blast ON". The blast wheel motor is started.
- Observe the ammeter in order to check the power consumption of the blast wheel motor. The motor requires a lot of power (starting current) when it is started until it reaches its maximum speed.
- Once the blast wheel has reached its rated speed the current drops to approx. 8 A no-load consumption.
- If the ammeter indicates more than the normal current value after 10 seconds, interrupt the power supply and find the cause.
- If the ammeter indicates a high load consumption after having reached the idle-running speed, the shot valve may be partially open or there may be another disturbance.
- Find out the cause of the disturbance and, if necessary, contact your **ISPC Blastrac/EBE** customer service engineer.

Initial operation

- ❑ Set the travel direction control valves (joysticks) to "forward" (working direction). Select the speed using the drive speed control valve.

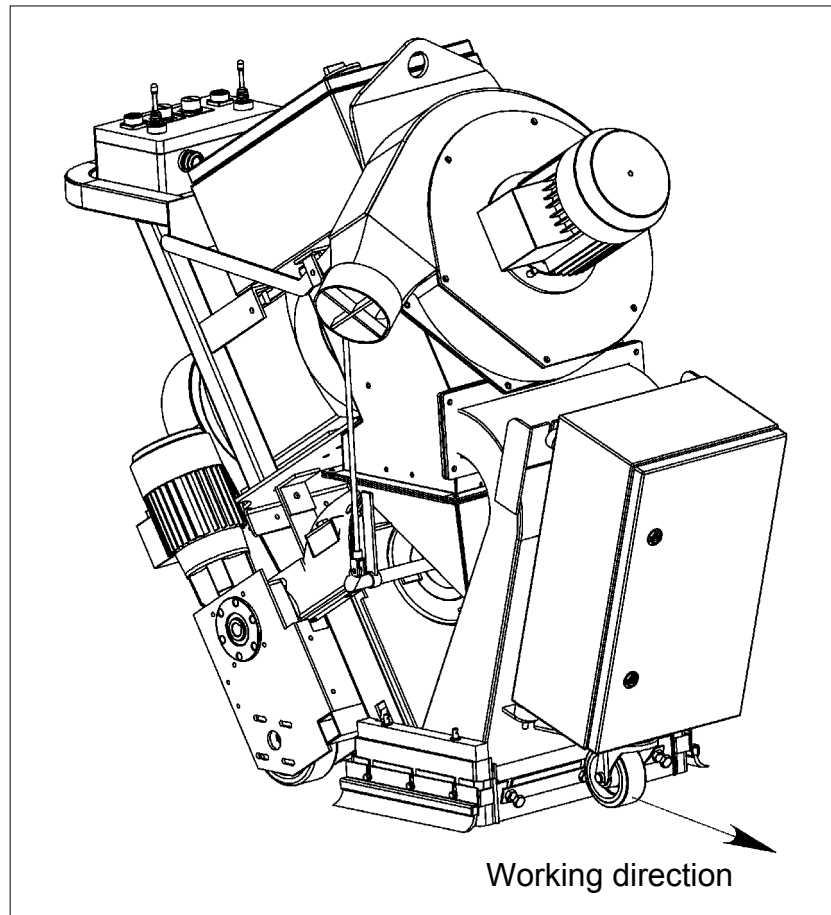

Fig. 5.2

When blast cleaning concrete the abrasive shot valve may only be opened when the blast cleaning machine is travelling! If the machine is at a standstill and the shot valve is open deep holes may be blasted into the concrete surface within seconds.

- ❑ When the machine is travelling, pull the abrasive control lever to operate the valve. Observe the ammeter. It may indicate the full load amperage (20 A max.).

Initial operation

- ❑ An indication exceeding the full load value means overloading of the motor, whereas an indication below the full load value shows that there is not enough abrasive fed to the blast wheel. If necessary re-adjust the abrasive shot valve handle that operates the shot valve or refill the hopper with abrasive.
- ❑ After having blasted approx. 2 m close the abrasive shot valve, stop the machine and check the blasted surface.
- ❑ If the blast pattern is irregular it may be necessary to re-adjust the blast pattern (see Chapter 7.5 “Setting the blast pattern”) or select another travel speed for the machine.

When the blast head is lifted from the floor, abrasive escapes from the sides of the blast head at high speed. If the machine is moved with the blast head raised, the abrasive shot valve must be closed and the blast motor must be off.



Alter the travel direction only after having closed the shot valve.



The dust container of the filter unit must be emptied regularly.



Contents Chapter 6

- 6.1 Operation
- 6.2 Electric drive system
- 6.3 Recommended blast paths
- 6.4 Switching-off the machine
- 6.5 What to do if a fault occurs
- 6.6 Safety shutdown
- 6.7 Restarting after a fault
- 6.8 Measures before and after long standstills

Operation

6.1 Operation

Normal start-up and operation of the blast machine EBE 350 E is no different from the procedure described in Chapter 5 “Initial operation”.

Carry out blasting in parallel tracks in such a way that the dust hose and electric cable do not become twisted.

Figure 6.1 shows the recommended blast paths leading away from the filter unit.

Make sure that no vehicles, such as forklift trucks and other equipment run over the electric cable and the dust hose.

The selection of the correct advancing speed of the blast machine is important for a good blast result. In the case that the surface has different characteristics (e.g. different hardness or different coating thicknesses), a uniform blast result can be achieved by varying the advancing speed during blast cleaning.

6.2 Electric drive system

The drive is an independent electric system contained within the drive control box at the front of the machine. There is an ON and an OFF switch on the control panel to operate the drive system.

Operation

Directional control

Controls the direction of electric power to the drive wheel motors. The control has a three position function; forward, reverse and neutral.

Left and right controls are independent from each other, giving instant forward, reverse and precise steering control as follows:

Both controls in forward position	:	Machine drives forwards
Both controls in reverse position	:	Machine drives backwards
One control forward, one control reverse	:	Machine turns around its centerpoint

In addition there is a tracking control rotating switch that controls one motor. Adjusting this switch at low speed ensures that the machine travels straight. For quicker response during higher speeds there are two wheel motor stop buttons. Pressing either of these will stop the wheel motor to which it is connected. This will give quick response steering.

Speed control rotating switch

Controls the current flow through the directional control switches to the drive wheel motors. Rotating the switch in anti-clockwise direction reduces the speed of the machine down to a dead slow. Thus by using the speed control switch, the forward/reverse speed of the machine is precisely controlled.

Abrasive shot valve handle

The abrasive shot valve handle operates the shot valve (inside the shot valve housing) between the abrasive storage hopper and the blast wheel. When the handle is pulled upwards, the shot valve is opened and abrasive is allowed to travel towards the blast wheel in a progressive, controlled manner.

Operation

6.3 Recommended blast paths

Position the filter unit near to a power supply connection.

Place the blast cleaning machine near to the filter unit and spread out the hose as shown in fig. 6.1.

Work with the blast cleaning machine, with the hose spread out in the opposite direction, repeating the process away from the filter unit.

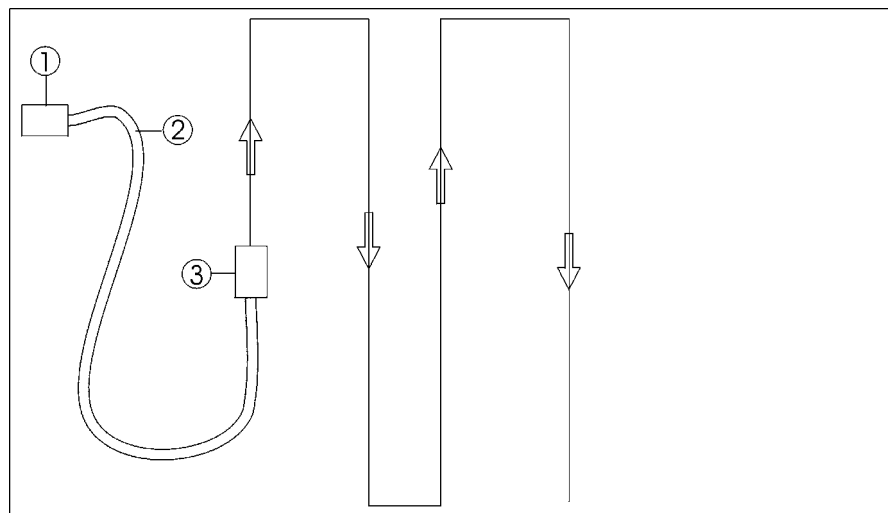

Fig. 6.1

- 1 Filter unit
- 2 Dust hose
- 3 Blast cleaning machine

Travel stepwise over the work area considering the service length of the dust hose.

Finish the blast cleaning process by blasting the area where the filter unit originally stood.

6.4 Switching-off the machine

- Shut off the abrasive supply by pushing down the shot valve handle.
- Advance the machine until you are sure that no deep holes are being blasted into the surface.
- Press the push button "Main blast OFF". This switches off the blast wheel motor.
- Press the push button "Fan OFF". This switches off the fan motor.
- Press the push button "Drive OFF". This switches off the drive motor.
- Set the main switch on the main box at the front of the blast cleaning machine to "OFF".
- After several minutes press the push buttons "Compressor OFF", "Fan OFF" and "Pulsator OFF" on the filter unit.
- Set the main switch of the filter unit to "OFF".

Make sure that all turning machine parts have come to standstill before any inspection or maintenance works are started.



When the **ISPC Blastrac/EBE** blast cleaning machine is put out of operation for a longer period of time, pull out the mains plug and cover the machine with a plastic foil.

Operation

6.5 What to do if a fault occurs

Irrespective of the following information, the local safety regulations are valid in any case for the operation of the machine.



First put the machine to its **Safety off position**. After that start looking for the defect.

6.6 Safety shutdown



The machine must be put to its safety off position before starting repair works. See Chapter 2 “Safety instructions”.

6

6.7 Restarting after a fault



See Chapter 5 “Initial operation”.



All persons in the proximity of the machine must wear safety glasses with lateral protection as well as safety shoes. The operator is obliged to wear close-fitting protective clothing.

6.8 Measures before and after long standstills

Standstill of the machine for a maximum of 3 months.

Before a long standstill period

Switch off the machine (see Chapter 6.4).

Protect the electric motors from moisture, heat, dust and shocks.

Clean the machine and cover it with a plastic foil.

Preserve bright parts of the machine and power pack with Tectyl 506, for example, or a similar preservative.

**After a long standstill period**

See Chapter 5 “Initial operation”.



Contents Chapter 7

- 7.1 Recommendations
- 7.2 Maintenance and inspection list
- 7.3 Repairing
- 7.4 The blast pattern
- 7.5 Setting the blast pattern
- 7.6 Setting the control cage
- 7.7 Wear parts
- 7.8 Blastwheel blades & Impeller replacement
- 7.9 Changing the liners



Maintenance

7.1 Recommendations



With maintenance and inspection works, please observe Chapter 2 "**Safety instructions**".

Failures due to inadequate or incorrect maintenance may generate very **high repair costs** and long standstill periods of the machine. **Regular** maintenance is therefore imperative.

Operational safety and service life of the machine depend, among other things, on proper maintenance.

The following table shows recommendations about time, inspection and maintenance for the normal use of the machine.

The time indications are based on uninterrupted operation. When the indicated number of working hours is not achieved during the corresponding period, the period can be extended. However a full overhaul must be carried out at least once a year.

Due to different working conditions it cannot be foreseen how frequently inspections for wear checking's, inspection, maintenance and repair works ought to be carried out. Prepare a suitable inspection schedule considering your own working conditions.

Our specialists will be happy to assist you with more advice.

7



Prior to any repair works on the machine and its drives, secure the machine against unintentional switching-on. Put the machine to its safety off position.



The supplier's operating and maintenance instructions should also be followed during service and maintenance.

Maintenance

7.2 Maintenance and inspection list

Operating hours/ time period	Inspection points, maintenance instructions
12 h after repairing	Check the efficiency of all safety devices. Check all accessible screw connections for tight seat.
every 3 h	Check whether there is any foreign matter in the hopper, the shot valve housing or in the blast wheel unit. Check blast wheel, liners and fasteners for wear and damage. Check the seal systems for wear. Check the electric connections for sediments of dirt or foreign bodies. Check the electric motors for dirt and other contaminants.
daily and prior to starting work	Check the hose connections for tightness and fixed seat. Check the hose to the filter for damages. Make sure that the dust container of the filter is emptied. Check blast wheel, liners and fasteners for wear and damage. Check the separator parts for wear and defects. Remove foreign bodies and dust deposits. Check the level of abrasive in the storage hopper. Top up if necessary. Check all connections of the electric cables for fixed seat, and check the cables for damage. Check the electric motors and connections for dirt and other contaminants.
annually	Full overhaul and cleaning of the complete machine.



Maintenance

7.3 Repairing



As already mentioned in Chapter 5 “Initial operation” we recommend to execute the first repair works on the machine with the help of **ISPC Blastrac/EBE** personnel. With this your maintenance personnel gets the opportunity to be trained intensely.

Only those repair works are described which occur within the context of maintenance or which are required to replace wear parts.

If you replace parts yourself for specific reasons, the following instructions and work sequence have to be observed.



You should also stock all spare or wear parts that cannot be supplied quickly. As a rule, production standstill periods are more expensive than the cost for the corresponding spare part.

Screws that have been removed must be replaced with those of the same quality (strength, material) and design.



Prior to any repair works on the machine and its drives, secure the machine against unintentional switching-on. Pull out the mains plug in order to do this.

7.4 The blast pattern

Abrasive leaving the blast wheel blades is not thrown in all directions. Scatter is restricted to an angle of about 80°. This is achieved through the use of a control cage which surrounds the impeller. The position of the window in the control cage determines the blast pattern.

Correct adjustment of the control cage and thus of the blast pattern is the most important factor for optimum working with the EBE 350 E blast cleaning machine.

Incorrect adjustment of the control cage results in very high wear and premature blasting-through of the liners in the blast wheel housing, as well as reduced blasting performance and a possible loss of the rebound energy of the abrasive.

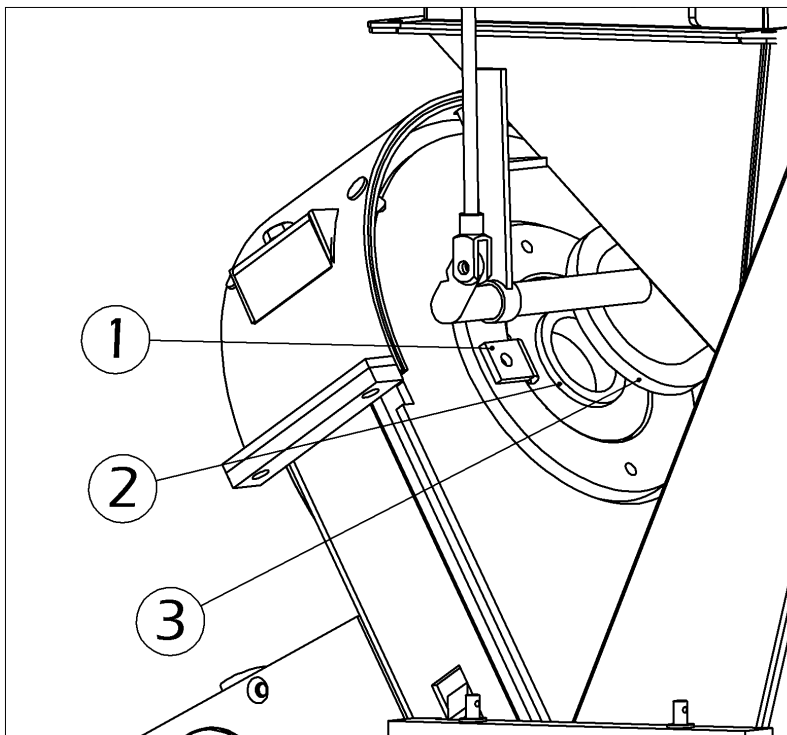

Fig. 7.1

- 1 Cage clamp
- 2 Control cage
- 3 Shot valve housing and Feed spout rubber

The adjustment is effected by loosening the cage clamps (pos.1) and turning of the control cage (pos.2).

Maintenance



Every time the control cage is replaced, the thread of the blast wheel fastening screw should be checked. Make sure that this screw will be tightened correctly. In addition, absolute care must be taken to clean the thread from dust and abrasive.

After each blast wheel repair work switch on the blast wheel motor for a short period (without feeding abrasive) in order to find out whether the rotating parts turn freely and without vibration. After that, the blast cleaning procedure can be continued.



The blast wheel motor is designed for a long service life. Damages to the blast wheel motor can be detected by unusual noises or functional failure of the electric motor. In this case notify our service department.

7.5 Setting the blast pattern

In order to obtain a uniform and perfect blast pattern on the surfaces to be treated, the correct adjustment of the blast pattern is of utmost importance.



Prior to any repair works on the machine and its drives, secure the machine against unintentional switching-on. Put the machine to its safety off position.

An incorrect adjustment of the blast pattern results in:

- Uneven cleaning (shadows on the right or left hand side).
- Extremely high wear of the blast wheel, blades, impellor, control cage and liners.

The following 4 factors affect the blast pattern:

Turning direction of the blast wheels:

- The turning direction of the blast wheel must correspond to the instructions on the housing (arrow indicating the turning direction).

Worn blast wheel parts:

- With increased wear of the blast wheel, blades, impeller and control cage, the blast pattern will change.

Size of abrasive:

- The size of the abrasive affects the blast pattern. With every exchange of abrasive, the blast pattern must be re-adjusted.

Position of the control cage:

- The correct adjustment of the control cage is the most important factor to obtain an optimum blast pattern. The control cage has a lateral window. The position of the window determines where the abrasive is fed onto the blast wheel blades and where it hits the surface to be treated.
- After each exchange of blast wheel parts, the adjustment of the control cage must be checked and re-adjusted by creating a blast pattern. The same applies for blasting on another type of surface.



Maintenance

7.6 Setting the control cage

The adjustment is effected by loosening the cage clamps and turning the control cage in the suitable direction. The cast groove on the control cage shows the central position of the control cage opening. The following adjustment standard value is valid: the control cage opening is approximately opposite to the throwing angle. The abrasive grain size plays an important role here. Different types of abrasive have different throwing characteristics due to their different weights and frictional resistance. This means that you must never use different types of abrasive at the same time.



Prior to any repair works on the machine and its drives, secure the machine against unintentional switching-on. Put the machine to its safety off position.



After fitting new spare parts always create a blast pattern in order to check the blasting direction. This is the only way to grant economical work and to avoid unnecessary wear and repair costs.

The adjustment can be carried out as follows:

- Determine the notch which indicates the centre of the window edges.
- If the blast wheel is turning counter-clockwise, set the notch of the control cage to imaginary 9.30 of a dial (fig. 7.2).

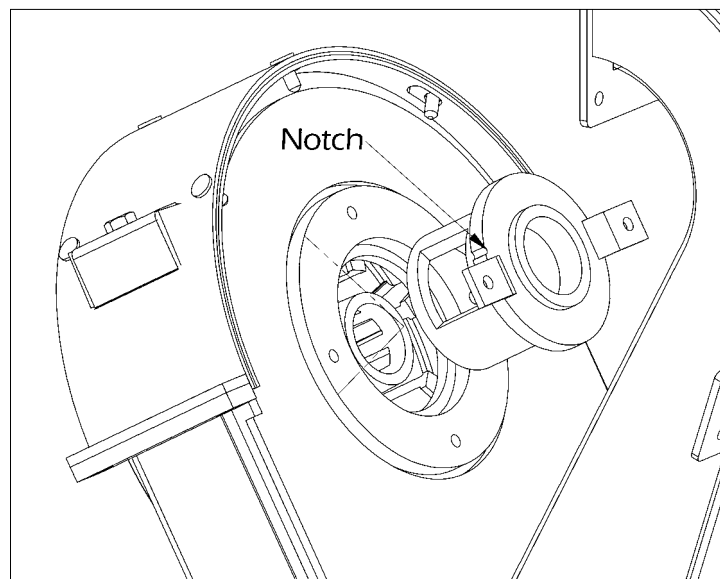

Fig. 7.2

Maintenance

- ❑ Move the blast head of the blast machine onto a 5-8 mm thick steel plate and blast for 15 seconds at full amperage without moving the machine from the spot.
- ❑ Stop the abrasive flow and move the machine forward until the blasted area is accessible. With both hands, **carefully** feel the temperature of the blasted area. You will find the hot spot on the blasted surface where the machine has developed the highest blast cleaning intensity.
- ❑ An even temperature from left to right indicates that the control cage is correctly positioned.
- ❑ Looking from the front side of the machine onto the control cage: If the left side of the blasted area is warmer, turn the notch of the control cage anti-clockwise for 3-6 mm. If the right side is warmer, turn the notch of the control cage clockwise for 3-6 mm.
- ❑ This process to be repeated until an even temperature across the blast pattern is achieved.
- ❑ Now the blasting procedure can be started. When a concrete surface is to be blasted, check the blast pattern again after some meters and re-adjust slightly if necessary. The blast pattern will change with an increased wear of the blast wheel, blades, impellor and control cage, and when the size of the employed abrasive is changed.

Never loosen the cage clamps or try to adjust the control cage when the machine is in operation.



Maintenance

7.7 Wear parts

The blast wheel parts

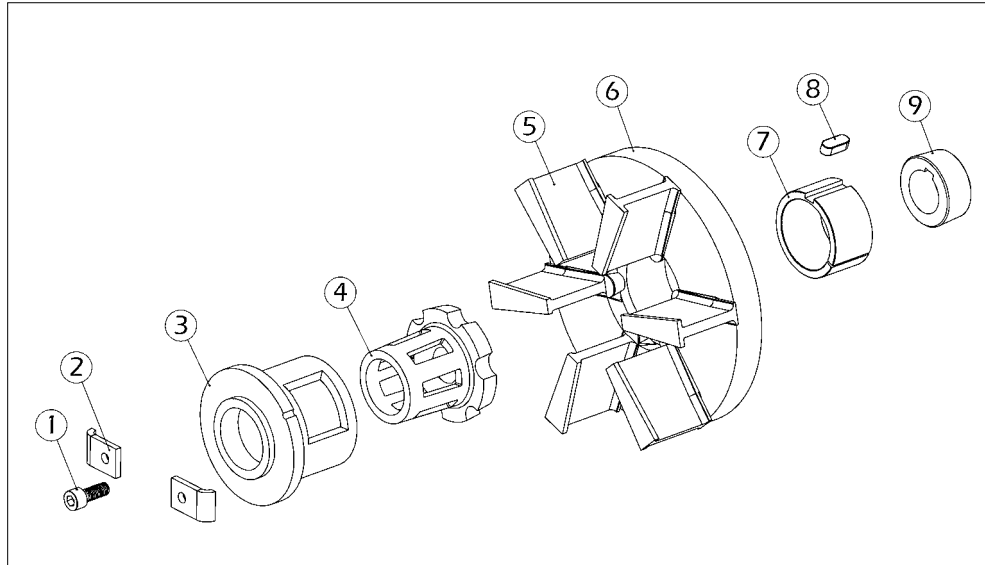

Fig. 7.3

- 1 Impeller bolt
- 2 Cage clamp
- 3 Cage
- 4 Impeller
- 5 Blades (set of 6)
- 6 Blastwheel
- 7 Taper lock adapter
- 8 Parallel key
- 9 Taper lock bush



The liners

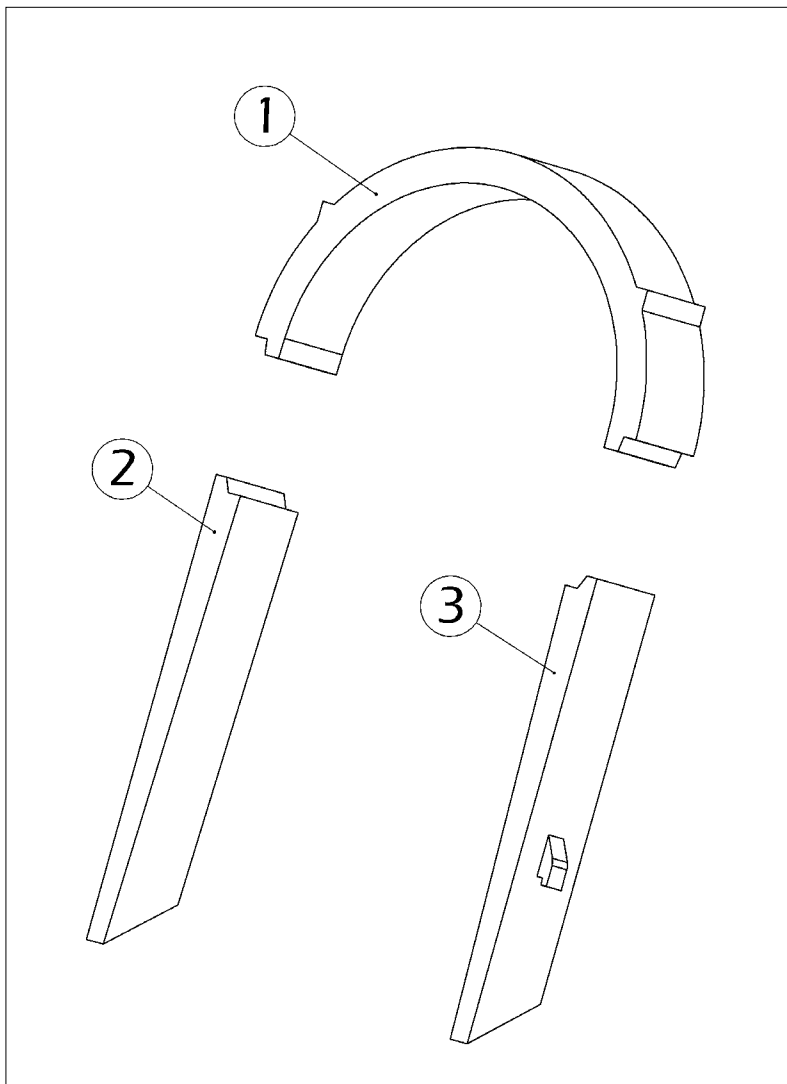

Fig. 7.4

- 1 Top liner
- 2 Right liner
- 3 Left liner

Maintenance

7.8 Blastwheel blades & Impeller replacement

During operation the blast wheel blades and the impeller will wear.

To replace worn components:

- Make sure the power unit is stopped and the main electricity supply disconnected.
- Remove the bolts securing the abrasive storage hopper to the separator and remove the hopper from the machine.
- Remove the cage clamps securing the control cage and remove the control cage.
- Unscrew the impeller bolt and remove the impeller using a wooden or brass drift.
- Clean the blast wheel and the blades with air.
- Tip the machine backwards on the floor. Through the opening at the bottom of the blast housing: remove the blades one by one using a wooden or brass drift.
- Clean the blast wheel thoroughly to make sure that the new blades and impeller will fit well and to avoid any imbalance of the blast wheel.
- Replace the blades with six new ones and re-assemble the machine in reverse order. Note: blast wheel blades must be replaced as a set. Replacing only some of the blades can cause imbalance of the blast wheel.

7.9 Changing the liners

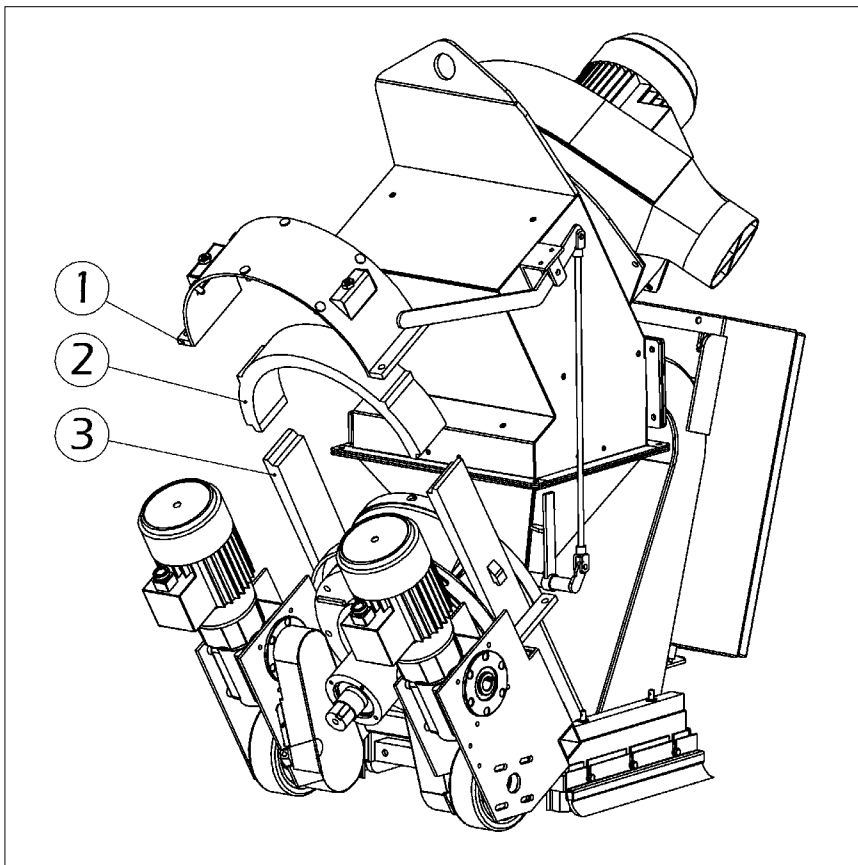

Fig. 7.5

- 1 Top liner cover
- 2 Top liner
- 3 Side liner

- Unscrew the top liner cover and remove it.
- Take the top liner out of the blast housing.
- Take out the left and right hand liners.
- Replace all worn items. Clean the liners and the inside of the blast housing thoroughly. Re-assemble the machine in reverse order, using kit between the top liner and the side liners, and between the top liner and the front and rear plates of the blast housing. Make sure that the top liner sits close at the edges of the side liners.

Contents Chapter 8

8.1 Electric circuit diagrams 350-9110-UNI

8.2 Electric circuit diagrams drive system 350-3006-E

PROJECT

Client :USF EBE B. V.
 Name :Blastmachine EBE 350
 S/E UniversalC

Particulars:

SUPPLIER

Draw. number :
 Order number :

Supplier : USF EBE B. V.
 Contact :
 Telephone : +31(0)30-6018866
 Telefax : +31(0)30-6018333
 Email :

DATA

Arch. number :PJ00.01027__A
 Calc. number :CL10096
 Status :As build

Start of project :14.03.2000
 Latest change :26.01.2001 (RJ0)

Highest page number : 13
 Number of pages : 13

			Start	14.03.2000	USF EBE B. V.		Frontpage	Arch. nr.	PJ00.01027__A	=	
			Eng.	RJ0	Blastmachine EBE 350			Draw. nr.		+	
			Print	11.02.2002	S/E UniversalC					Pages	13
Change	Date	Name	Status	As build						Page	1

Wire Color:

Main-Voltage

- L1 -Black
- L2 -Black
- L3 -Black
- N -Blue
- PE/⊕ -Yellow/Green

Control-Voltage

- 24VAC-A -White
- 24VAC-B -White

Example Codification:

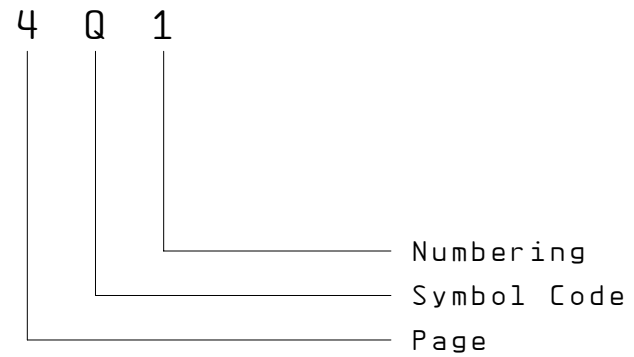

			Start	14.03.2000	USF EBE B.V. Blastmachine EBE 350 S/E UniversalC	Wiring dates	Arch. nr.	PJ00.01027__A		=
			Eng.	RJO			Draw. nr.			+
			Print	11.02.2002			Pages	13	Page	3
Change	Date	Name	Status	As build						

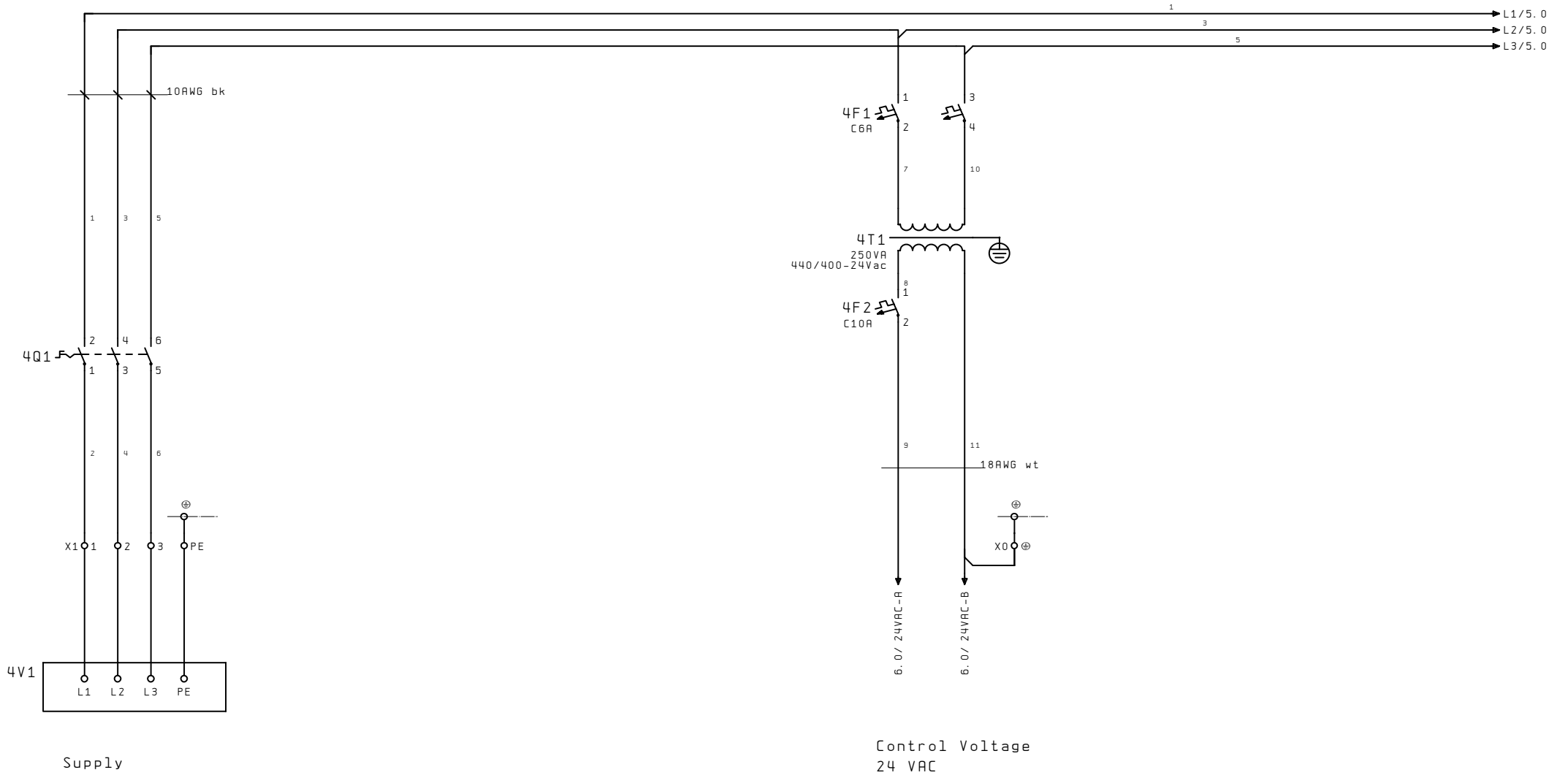

Start	14.03.2000	USF EBE B.V. Blastmachine EBE 350 S/E UniversalC	Supply	Arch. nr.	PJ00.01027__A	
Eng.	RJO			Draw. nr.	Pages	Page
Print	11.02.2002				13	4
Change	Date	Name	Status	As build		

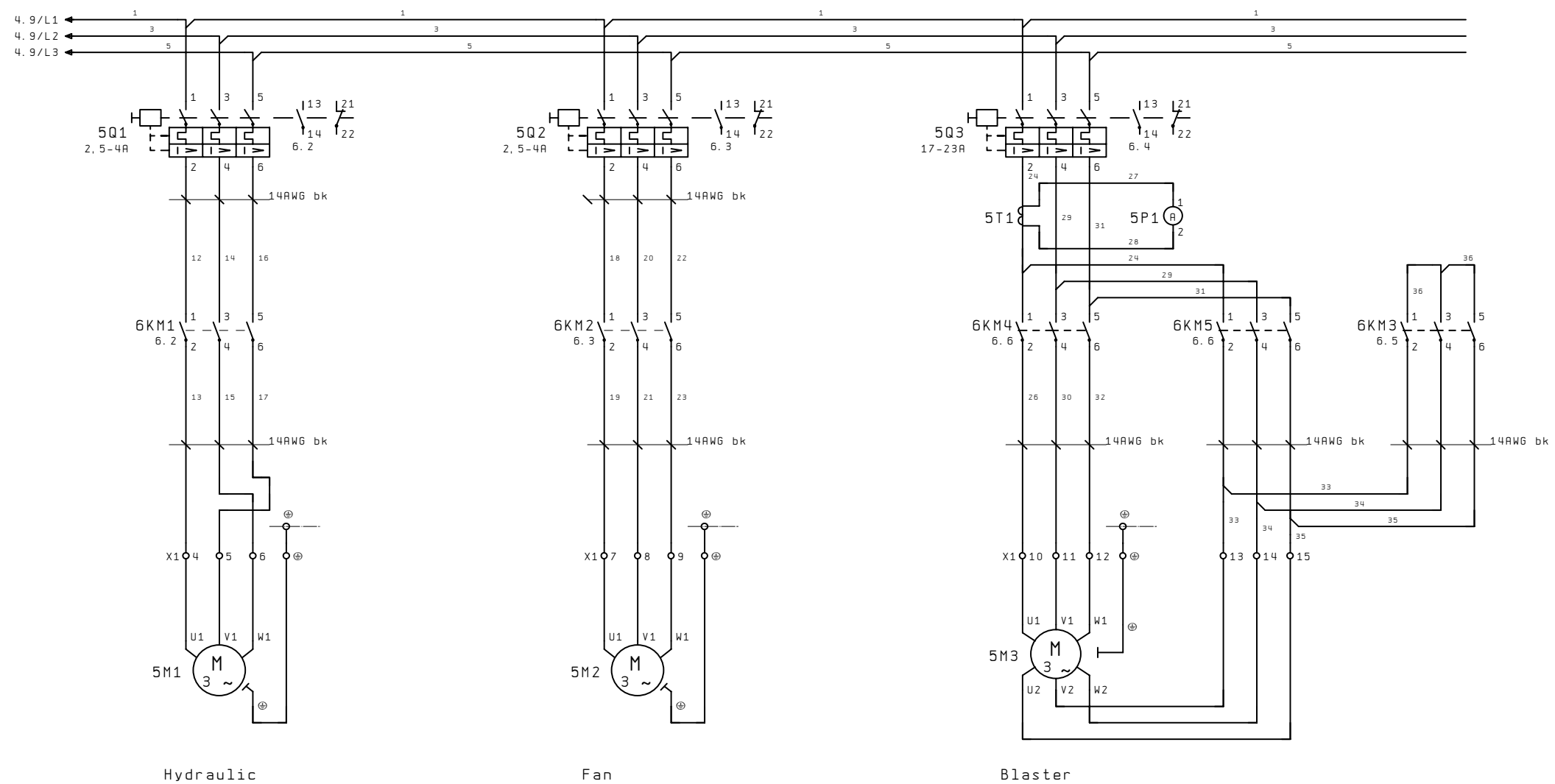

Hydraulic

Fan

Blaster

Start	14.03.2000	USF EBE B.V. Blastmachine EBE 350 S/E UniversalC	Main-Voltage	Arch. nr.	PJ00.01027__A	
Eng.	RJO			Draw. nr.	Pages	Page
Print	11.02.2002				13	5
Change	Date	Name	Status	As build		

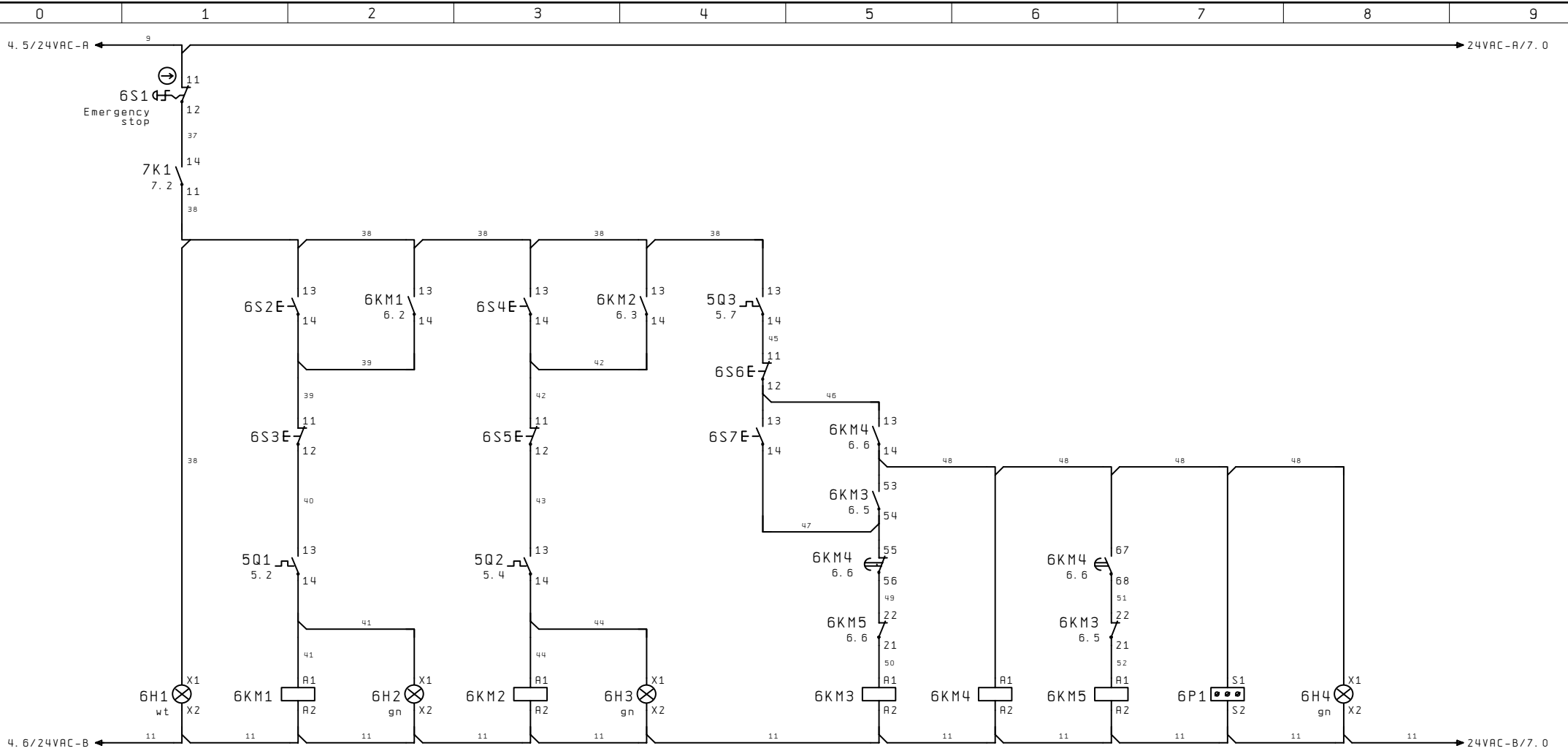

Control
Voltage
Present

1 - 2 5.1
3 - 4 5.1
5 - 6 5.1
13 - 14 6.2

Hydraulic

Fan

1 - 2 5.4
3 - 4 5.4
5 - 6 5.4
13 - 14 6.4

Blaster

1 - 2 5.8
3 - 4 5.9
5 - 6 5.9
21 - 22 6.6
53 - 54 6.5

1 - 2 5.6
3 - 4 5.6
5 - 6 5.6
13 - 14 6.5
55 - 56 6.5

67 - 68 6.6

Operating-
time
Counter

1 - 2 5.7
3 - 4 5.7
5 - 6 5.8
21 - 22 6.5

5				Start	14.03.2000	USF EBE B. V. Blastmachine EBE 350 S/E UniversalC	Control-Voltage		Arch. nr.	PJ00.01027__A		=	
				Eng.	RJO				Draw. nr.			+	
				Print	11.02.2002				Pages			Page	
Change	Date	Name	Status	As build								13	



Detection

11 -> 14 6.1

X1

Internal connection	401: 1	401: 3	401: 5	⊕	6KM1: 2	6KM1: 6	6KM1: 4	⊕	6KM2: 2	6KM2: 4	6KM2: 6	⊕	6KM4: 2	6KM4: 4	6KM4: 6	⊕	6KM5: 2	6KM5: 4	6KM5: 6
Bridges																			
Terminal	1	2	3	PE	4	5	6	⊕	7	8	9	⊕	10	11	12	⊕	13	14	15

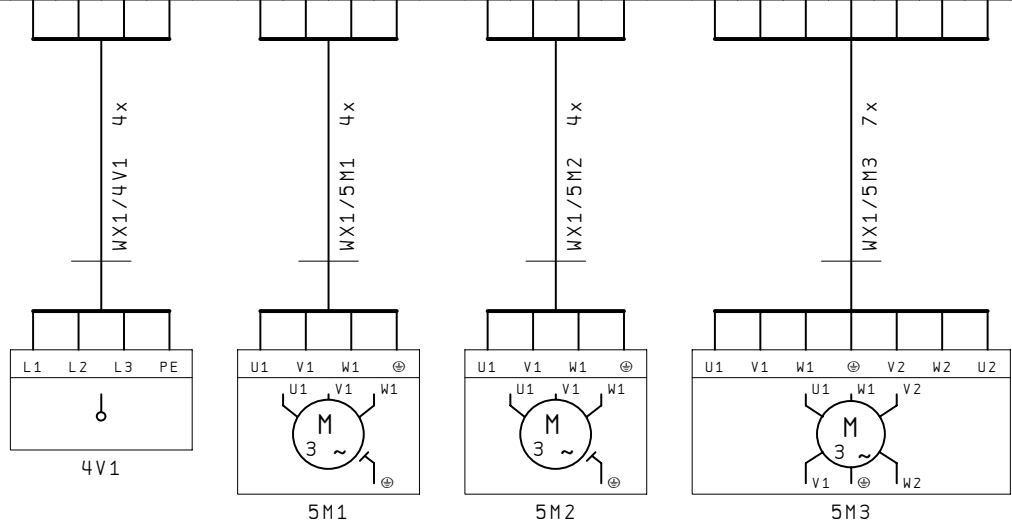

Supply
 =
 =
 =

Hydraulic
 =
 =
 =

Fan
 =
 =
 =

Blaster
 =
 =
 =
 =
 =
 =

Start	14.03.2000	USF EBE B. V. Blastmachine EBE 350 S/E UniversalC	Power conection	Arch. nr. PJ00.01027__A	=	
Eng.	RJO				+	
Print	11.02.2002				Pages	Page
Change	Date	Name	Status	As build	13	8

X2

Internal connection		6H4: X2			
		7K1: R2			
		6S1: I1			
		7K1: R1			
Bridges					
Terminal	1	2	3	4	

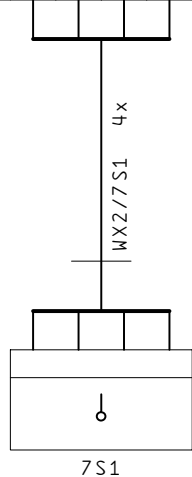

Detection
= = =

Start	14.03.2000	USF EBE B.V. Blastmachine EBE 350 S/E UniversalC	Detection	Arch. nr.	PJ00.01027__A	
Eng.	RJ0			Pages	13	
Print	11.02.2002			Page	9	
Change	Date	Name	Status	As build		

Frontview

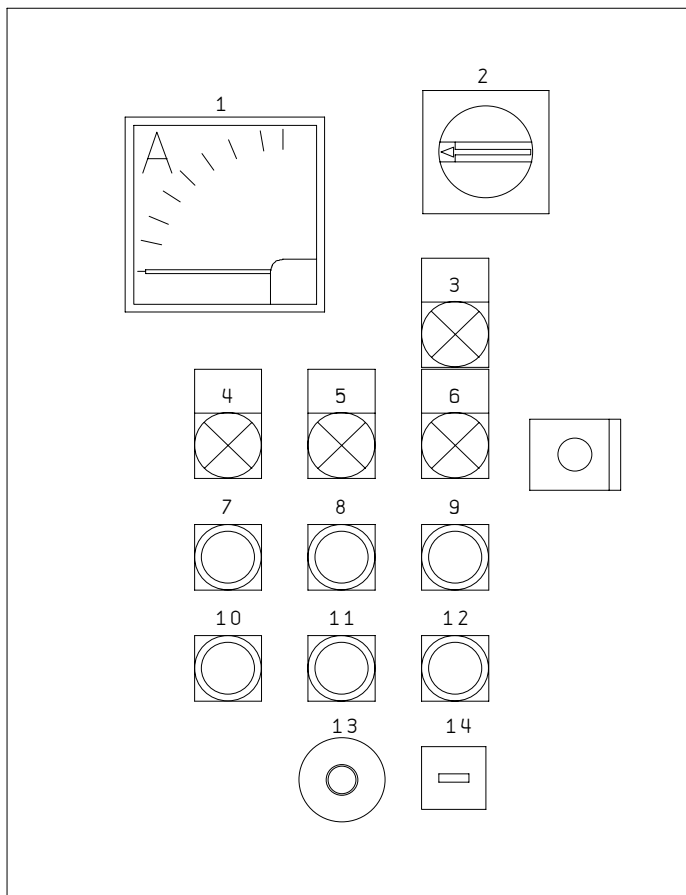

- 1: 5P1 Ammeter
- 2: 4Q1 Main switch
- 3: 6H1 Control Voltage
- 4: 6H2 Drive
- 5: 6H3 Fan
- 6: 6H4 Main Blast
- 7: 6S2 Start Drive
- 8: 6S4 Start Fan
- 9: 6S7 Start Main Blast
- 10: 6S3 Stop Drive
- 11: 6S5 Stop Fan
- 12: 6S6 Stop Main Blast
- 13: 6S1 Emergency Stop
- 14: 6P1 Operating Time Counter

			Start	14.03.2000	USF EBE B.V. Blastmachine EBE 350 S/E UniversalC	Frontview	Arch. nr.	PJ00.01027__A			
			Eng.	RJO			Draw. nr.	Pages	13	Page	12
Change	Date	Name	Status	As build							

Mountingplate

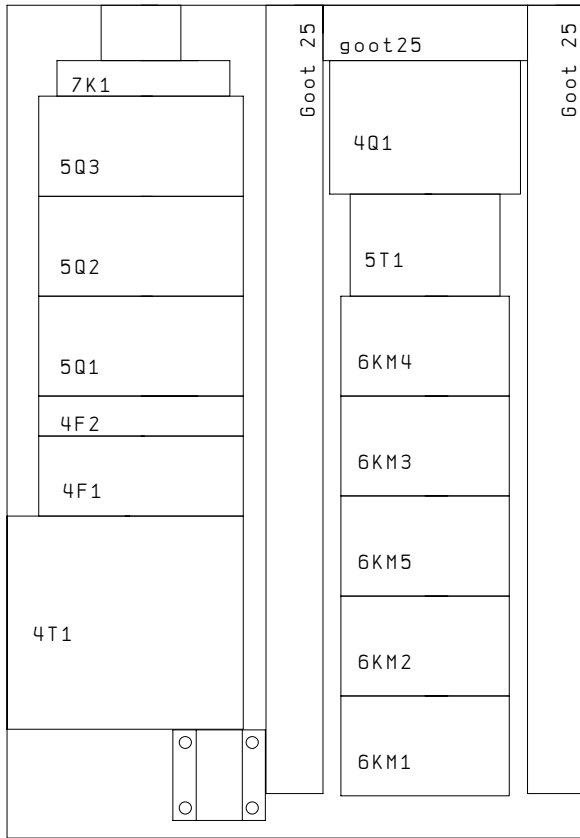

			Start	14.03.2000	USF EBE B.V. Blastmachine EBE 350 S/E UniversalC	Mountingplate division	Arch. nr.	PJ00.01027__A		=
			Eng.	RJO			Draw. nr.			+
			Print	11.02.2002			Pages	13	Page	13
Change	Date	Name	Status	As build						

Details:

PROJECT
 Client : USF EBE B.V.
 Name : 350 Drive-system

CONTRACTOR
 Drawing No. :
 Order No. :
 Contractor : USF EBE B.V.
 Contact :
 Telephone : +31(0)30-6018866
 Fax : +31(0)30-6018333
 Email :

REMARKS
 Archives No. : 350-3006-E
 Calculate No.:
 Status :

Created at : 10. january.2001 (JPP) Last pagenumber : 18
 Last revision at : 8.may.2001 (JPP) Number op pages : 18

Start	10.january.2000	USF EBE B.V.	Arch.No.	350-3006-E	=	
Draw.	JPP	350 Drive-system	Draw.No.		+	
Print				Pages	18
Status				Page	1

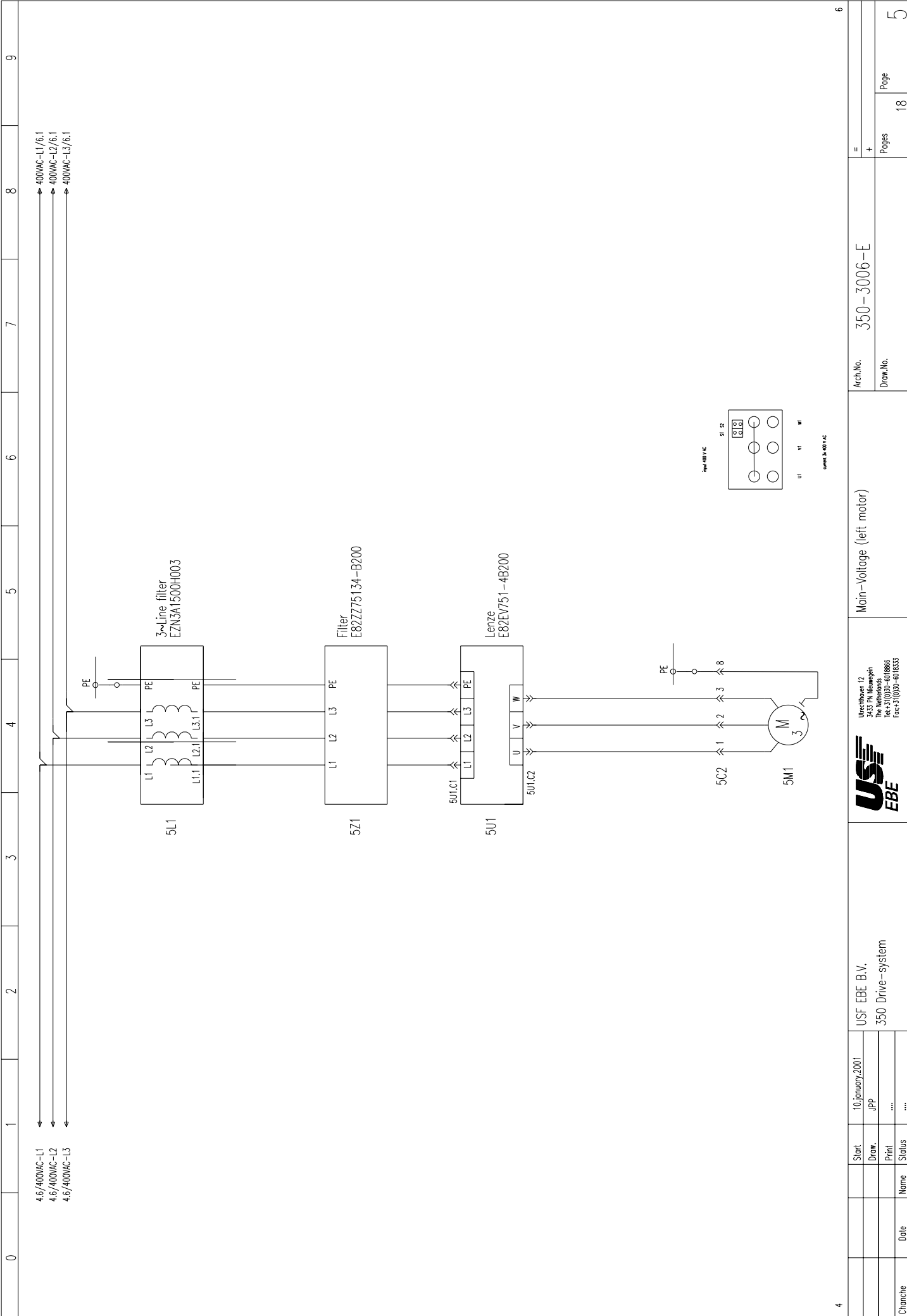

0	1	2	3	4	5	6	7	8	9
4									
Start	10 January 2001								
Draw.	JPP								
Print								
Status								
Chanche	Date	Name	Status						
				USF EBE B.V.	Main-Voltage (left motor)				
				350 Drive-system	Arch. No. 350-3006-E				
					Draw. No.				
					Pages 18				
					Page 5				



Utrechtsehaven 12
3433 PH Niemegein
The Netherlands
Tel: +31 (0)30 6018866
Fax: +31 (0)30 6018833

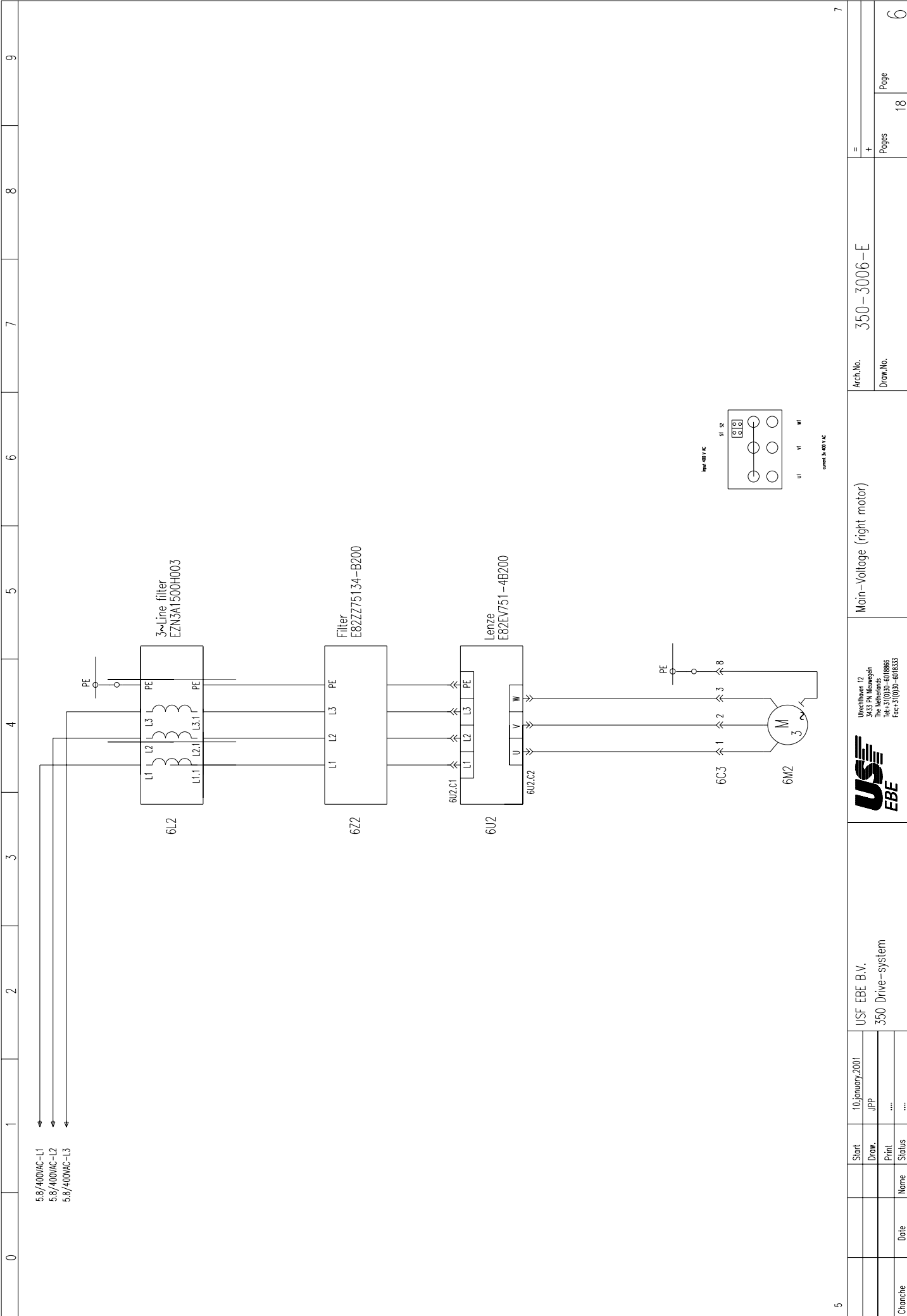

5.8/400VAC-L1
 5.8/400VAC-L2
 5.8/400VAC-L3

3-phase filter
 EZN3A1500H003

Filter
 E8ZZ75134-B200

Lenze
 E82EV751-4B200

Start	10 January 2001
Drawn	JPP
Print
Status

USF EBE B.V.
 350 Drive-system

Utrechtsebaan 12
 3433 PA Meeuwen
 The Netherlands 611866
 Tel: +31(0)30-618866
 Fax: +31(0)30-618833



Arch. No. 350-3006-E
 Draw. No.

Chanche	Date	Name	Status

0	1	2	3	4	5	6	7	8	9
5C2									
Internal connection	5U1C1U	5U1C1V	5U1C1W	X1:12	X1:20				
Bridge									
Terminal	1	2	3	4	5				

5M1

701

Drivermotor left

Thermal safeguarding left motor



Utrechtlaan 12
3433 PH Nieuwegein
The Netherlands
Tel: +31 (0)30 4018866
Fax: +31 (0)30 4018833

0	1	2	3	4	5	6	7	8	9	
6C3										
Internal connection	6U2.C1:U	2	6U2.C1:V	3	6U2.C1:W		X1:9	5	X1:13	6
Bridge										
Terminal	1		2		3					

Driver motor right

Thermal safeguarding
right motor



Utrechtsehaven 12
3433 PH Meeuwegijn
The Netherlands
Tel: +31 (0)30 4018866
Fax: +31 (0)30 4018833

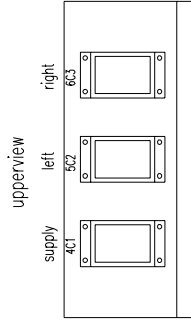

Left-sideview

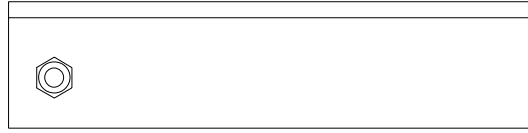

Frontview



Upper filter: 5Z1
Lower filter: 6Z2

Mountingplate

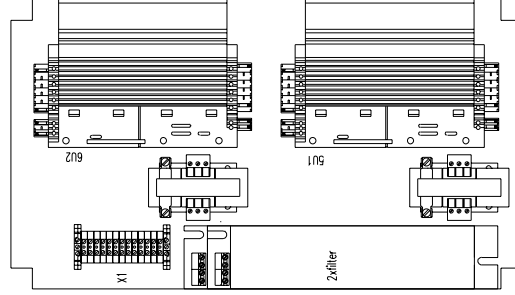

Enclosure

Make : Rittal
Type : KL1509210
Dim. : 500x300x120
Color : RAL 7032

Chonche	Date	Name	Status	12.juni.2000	USF EBE B.V.	 <p>Utrechtsehaven 12 3433 PH Nievegein The Netherlands Tel: +31 (0)30 4018866 Fax: +31 (0)30 4018833</p>	Panel layout (main box)	Arch.No.	350-3006-E	= +	Pages	18
	Draw.No.	14	Pages	14								

Mountingplate

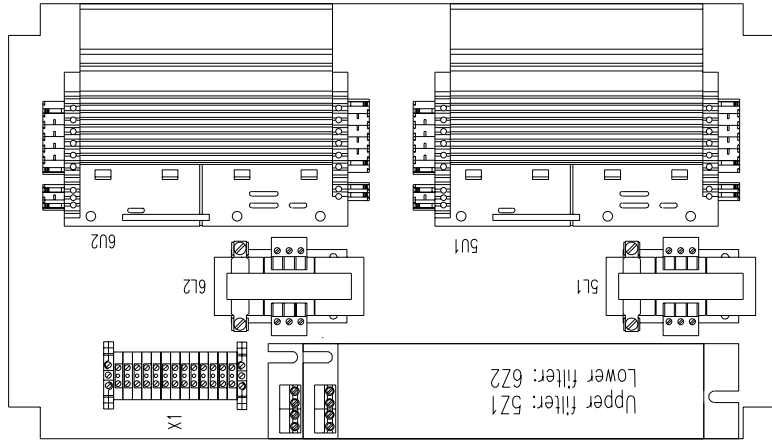

Enclosure

Make : Rittal
 Type : KL1509210
 Dim. : 500x300x120
 Color : RAL 7032

16	13.juni.2000	Start	JPP	USF EBE B.V.	13.juni.2000	18	=	+	Arch.No. 350-3006-E	Mountingplate division	Utrechtlaan 12 3433 PH Niemegein The Netherlands Tel: +31 (0)30-618866 Fax: +31(0)30-618833		USF EBE B.V. 350 Drive-system	Pages	18	17
														Draw.No.		

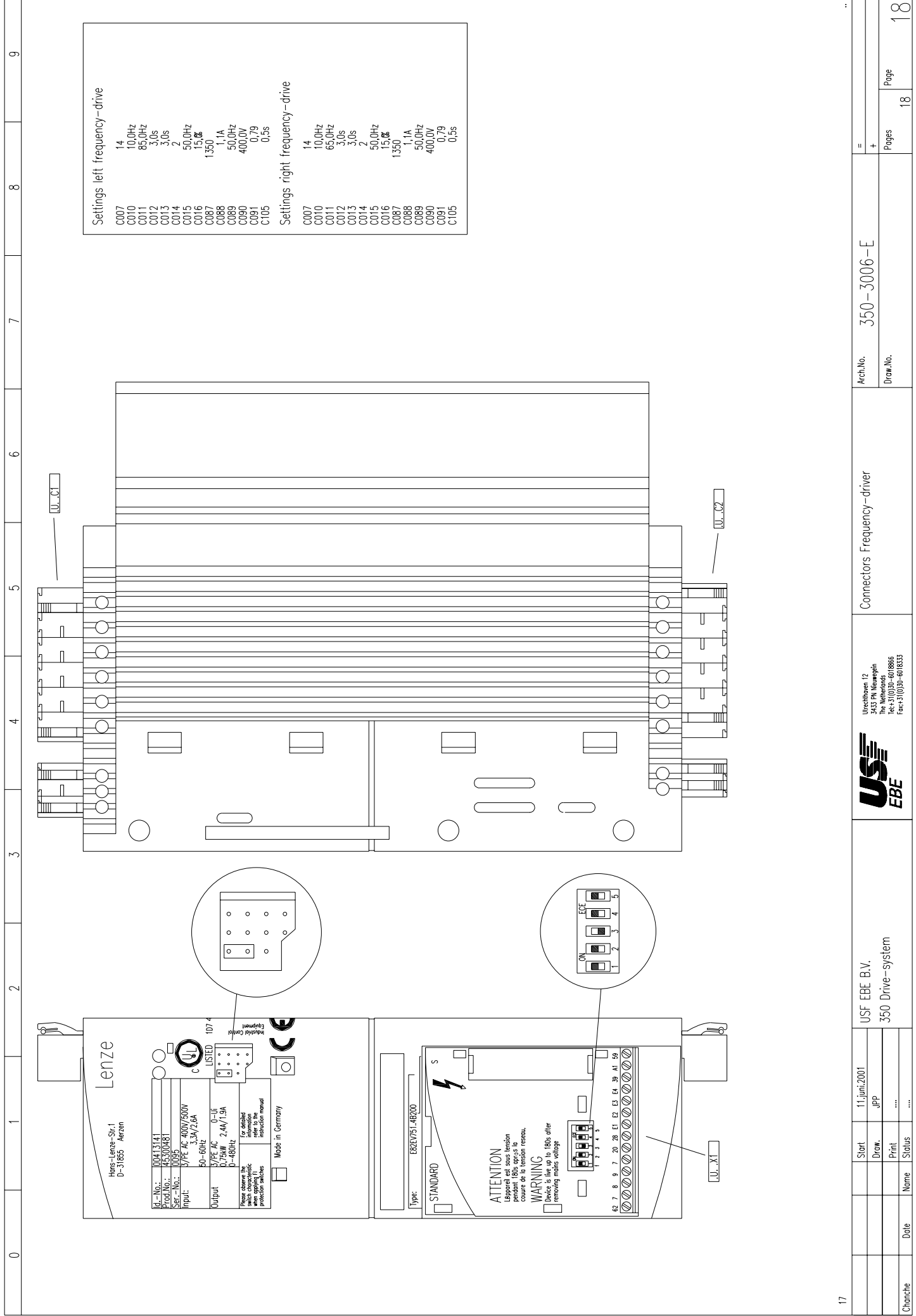

Settings left frequency-drive	
C007	14
C010	10.0Hz
C011	85.0Hz
C012	3.0s
C013	3.0s
C014	2
C015	50.0Hz
C016	15.0%
C087	1350
C088	1.1A
C089	50.0Hz
C090	400.0V
C091	0.79
C105	0.5s

Settings right frequency-drive	
C007	14
C010	10.0Hz
C011	65.0Hz
C012	3.0s
C013	3.0s
C014	2
C015	50.0Hz
C016	15.0%
C087	1350
C088	1.1A
C089	50.0Hz
C090	400.0V
C091	0.79
C105	0.5s

Start	11.juni.2001	USF EBE B.V.	Connectors Frequency-drive	Arch.No. 350-3006-E	=
Draw.	JPP				
Print	USF EBE Utrechtsehaven 12 3433 PH Nieuwegein The Netherlands Tel: +31 (0)30 6618866 Fax: +31 (0)30 6618833	Draw.No.	Pages	18
Status				

Contents Chapter 9

9.1 Fault diagnosis - blast machine

9.2 Fault diagnosis - electrical system

Fault diagnosis

9.1 Fault diagnosis - blast machine



Prior to any repair works on the machine or its drives the machine must be secured against unintentional switching-on. Put the machine to its Safety off position.

Fault	Possible cause	Remedy
Excessive vibration	Blast wheel is worn irregularly. Imbalance due to worn or broken wheel blades.	Replace the worn blast wheel parts and remove all broken parts from the machine.
	Machine fan impeller is worn.	Replace the worn fan impeller.
Unusual noise	Too little play or poor alignment of the rotating parts.	Check alignment of the rotating parts (blast wheel and control cage).
	Loose and incorrect set screws.	Check whether all screws and parts are fixed tightly).
	Squeaking wheels.	Replace the wheels.
	Seizing motor.	Replace the motor.
Reduced or no blasting performance	Inadequate abrasive supply to the blast wheel.	Clean wire mesh, top up abrasive if necessary.
	Contaminated abrasive.	Abrasive is heavily contaminated, check the ventilation system.
	Feeding of abrasive shot valve and abrasive storage hopper.	Check and clean blocked shot valve housing.

Fault diagnosis

Fault	Possible cause	Remedy
Reduced or no blasting performance	Blast wheel or control cage.	Worn blast wheel or control cage, replace worn parts if necessary.
	Adjustment of the shot valve.	Check the adjustment of the valve.
	"Shocked blast wheel". At the start of the blast process too much abrasive at once hits the wheel.	Close the shot valve and stop the blast wheel motor. Start the blast process again and slowly open the valve.
	The travel speed is too high.	Reduce the travel speed.
Escaping abrasive	Poor sealing.	Check all seals and replace if necessary.
Abrasive loss on the surface or escaping abrasive at the blast head	Poor abrasive quality.	Contact ISPC Blastrac/EBE .
	Worn blast wheel parts.	Replace worn blast wheel parts.
Contaminated abrasive	The filter unit is not generating enough suction power so that dust remains in the abrasive.	Check the filter unit (cartridges and seals).

Fault diagnosis

Fault	Possible cause	Remedy
Excessive wear in blast housing and recovery duct	Wrong abrasive. Incorrect setting of the control cage	Contact ISPC Blastrac/EBE . The thrown abrasive blasts the housing and not the surface to be blasted. Adjust the blast pattern.
Machine is not moving	The travel speed is too low.	Increase the travel speed.

9.2 Fault diagnosis - electrical system



Prior to any repair works on the machine or its drives the machine must be secured against unintentional switching-on. Put the machine to its Safety off position.

Fault	Possible cause	Remedy
Control system does not switch on	Motor protection switch has triggered.	Check and switch on again. Check the mains power supply.

Fault diagnosis

Fault	Possible cause	Remedy
Control system switches off during operation	Connection cable is defective.	Replace the cable.
	Cables connecting the units (travel motor, etc.) are defective.	Replace the cable.
	Motor protection switch has triggered.	Have the fault checked by an electrician.
	Main switch of the filter unit switches off due to overload.	Switch the main switch "ON" - with fault, have the unit checked by an electrician.
Machine does not travel	Fuse defective or short circuit in the travel motor lead or tachometer lead, motor defective.	Have the unit checked by an electrician.
	Control unit defective.	Replace the control unit.
	Potentiometer defective.	Replace the potentiometer.

Note: If the motor protection switch of the blast wheel motor has been triggered by overload, it can be switched on again after a short cooling down period.

Contents Chapter 10

10.1 Spare parts

Spare parts

10.1 Spare parts

Blast housing and seals

Item	Part no.	Description	Qty.
1	-	Bolt M10x50 + 2 x Nut M10	3
2	350-1059-SE	Locating plate outer	1
3	350-1054-SE	Front skirt outer	1
4	-	Front seal angle (part of blast housing)	1
5	350-1053-SE	Front skirt intermediate	1
6	350-1058-SE	Front locating plate inner	1
7	350-1057-SE	Front skirt fixing plate	1
8	350-1052-SE	Front skirt inner	1
9	350-9006-E	Blast housing cabinet	1
10	350-2010-SEV	Front wheel castor complete	1
11	350-1021-SE	Side seal spring plate	2
12	350-1020-SE	Side seal (set of 2)	1
13	350-1060-SE	Side skirt (set of 2)	1
14	350-1061-SE	Side skirt fixing plate	2
15	350-1050-SE	Side brush (set of 2)	1
16	-	Bolt M6x16 + washer + spring lock washer	6
17	350-1045-SE	Back brush	1
18	350-1047-SE	Back brush skirt	1
19	350-1115	Top liner cover	1

Spare parts

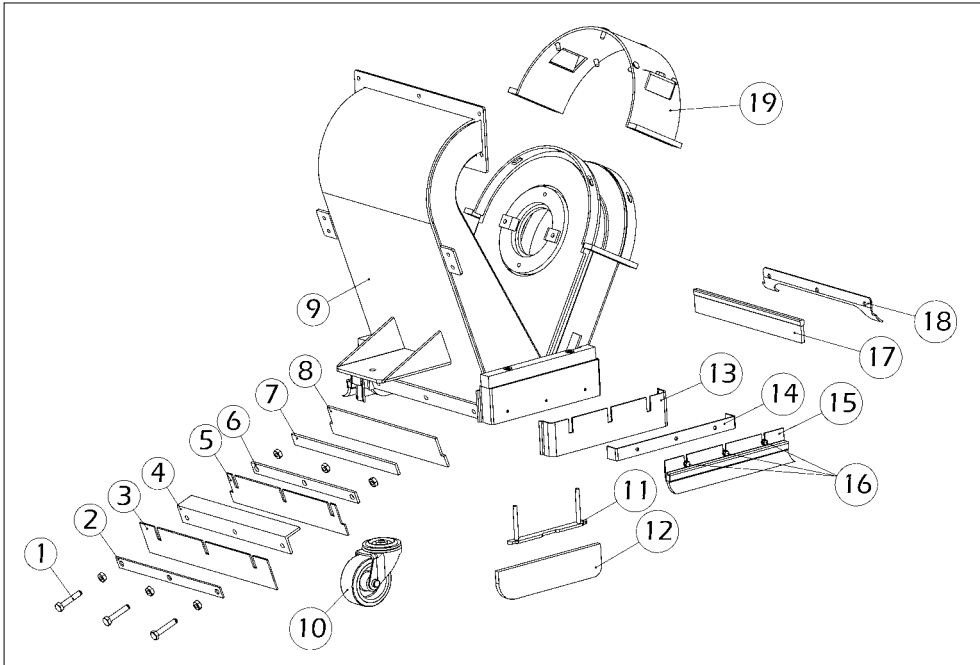

Fig. 10.1

Spare parts

Blast wheel parts and liners

Item	Part no.	Description	Qty.
1	350-1245-SEV	Impeller bolt	1
2	350-9041	Cage clamp	2
3	350-1010	Control cage	1
4	350-1015	Impeller	1
5	350-1025	Blastwheel	1
6	350-1005	Blades (set of 6)	1
7	222-2265	Taperlock adapter blastwheel	1
8	222-2290	Blastwheel shaft taperlock bush	1
9	350-1040	Top liner	1
10	350-1035-SE	Liner RH	1
11	350-1030-SE	Liner LH	1

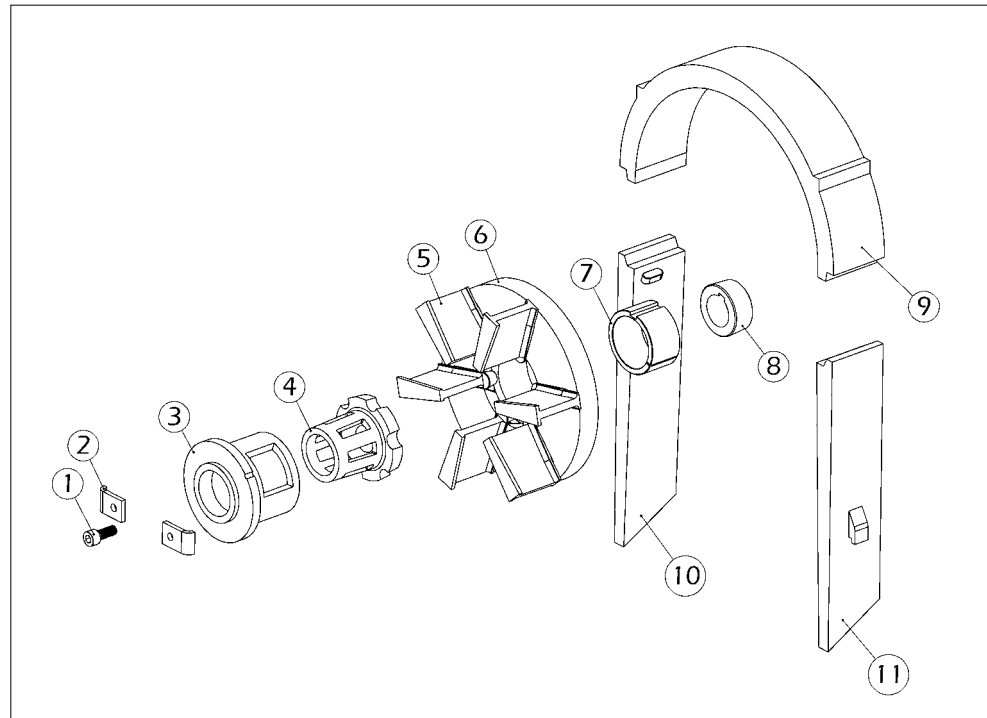

Fig. 10.2

Separator and hopper

Item	Part no.	Description	Qty.
1	350-9120-SE	Separator housing	1
2	350-9112-SE	Shot valve handle	1
3	350-1069-SE	Shot lever shaft complete	1
4	350-9119-SE	Separator door	1
5	350-9117-SE	Separator drawer lock plate	1
6	350-1111-SE	Separator tray	1
7	350-9118-SE	Baffle plates	1
8	350-1067-SE	Abrasive storage hopper	1
9	350-2015-SE	Shot valve axle	1
10	350-9240-S	Shot valve axle housing	1
11	350-1071-SE	Shot valve insert steel	2
12	350-1070-SE	Shot valve insert rubber	1
13	350-1065-SE	Feed spout rubber	1

Spare parts

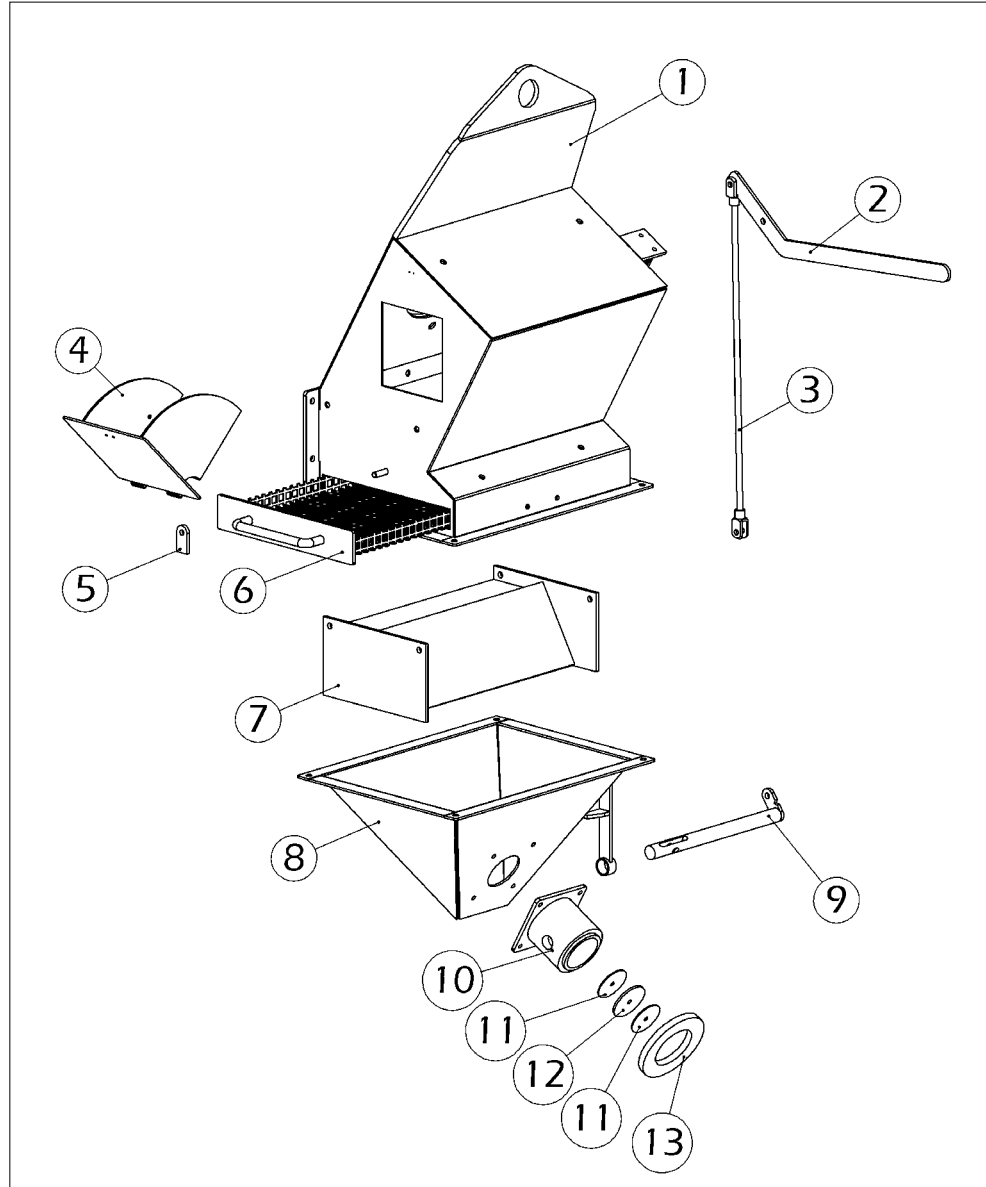

Fig. 10.3

Fan Unit

Item	Part no.	Description	Qty.
1	350-3055-S	Fan motor 1.5 kW	1
2	350-9030	Fan housing plate (top)	1
3	350-1085 SE	Fan impeller	1
4	350-1090-SE	Fan housing	1
5	350-9025	Fan housing plate (bottom)	1
6	035-9035	Fan ring	1
7	035-1125	Fan housing seal	1

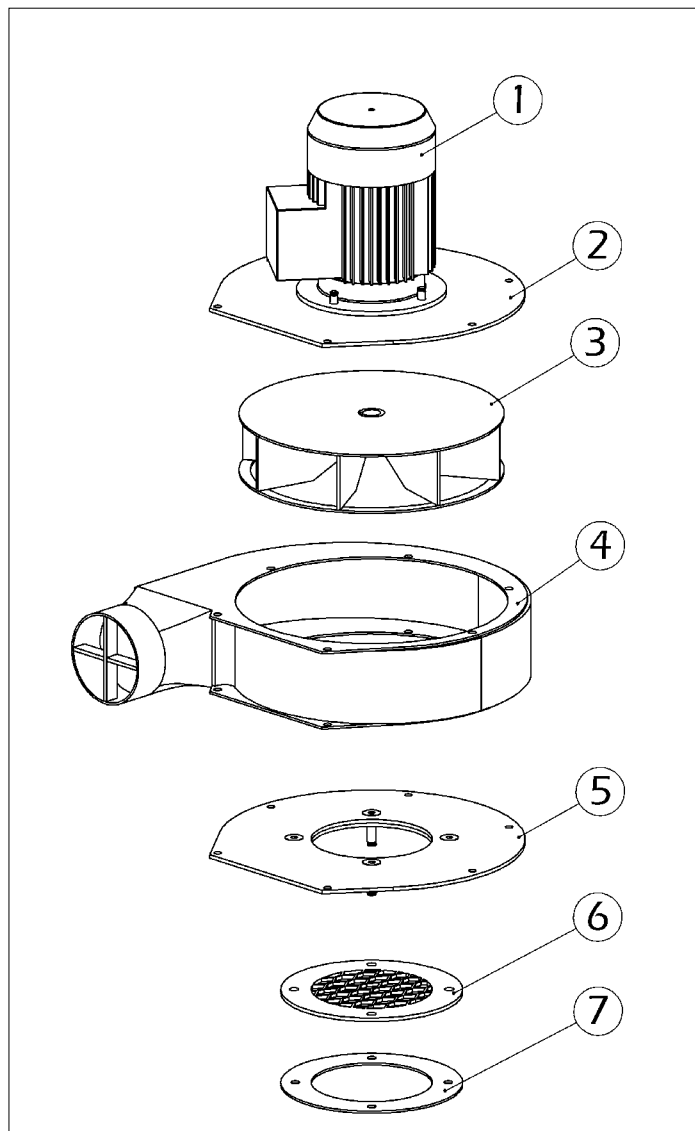

Fig. 10.4

Spare parts

Control handle and blast wheel drive

Item	Part no.	Description	Qty.	Hz.
1	350-9110-UNI	Control box UNI	1	
2	350-3006-E	Electric drive system AC	1	
3	350-9085-E	Handle complete	1	
4	350-3020-SEP	Blastmotor 11kW	1	
5	350-2170	Belt pulley (50Hz)	1	50Hz
	350-2180	Belt pulley (60Hz)	1	60Hz
6	222-2171	Taperlock bush	1	50/60Hz
7	350-2430-S	Blastmotor belt	1	
8	350-9255-S	Belt guard complete	1	
9	-	Bolt M10x25 + washer Ø40	1	
10	222-2290	Blastwheel shaft taperl. bush (60Hz)	1	60Hz
11	350-2175	Belt pulley (50Hz)	1	50Hz
	350-2345	Belt pulley (60Hz)	1	60Hz
12+13	350-9027-SE	Belt guard back plates	1	
14	350-2464-SEVU	Blast wheel shaft spacer 8mm	1	50Hz
	350-2463-SEVU	Blast wheel shaft spacer 32mm	1	60Hz
15	350-2451-SEV	Blastwheel bearing house complete	1	
16	350-9007-SEVU	Blast motor mount plate	1	

Spare parts

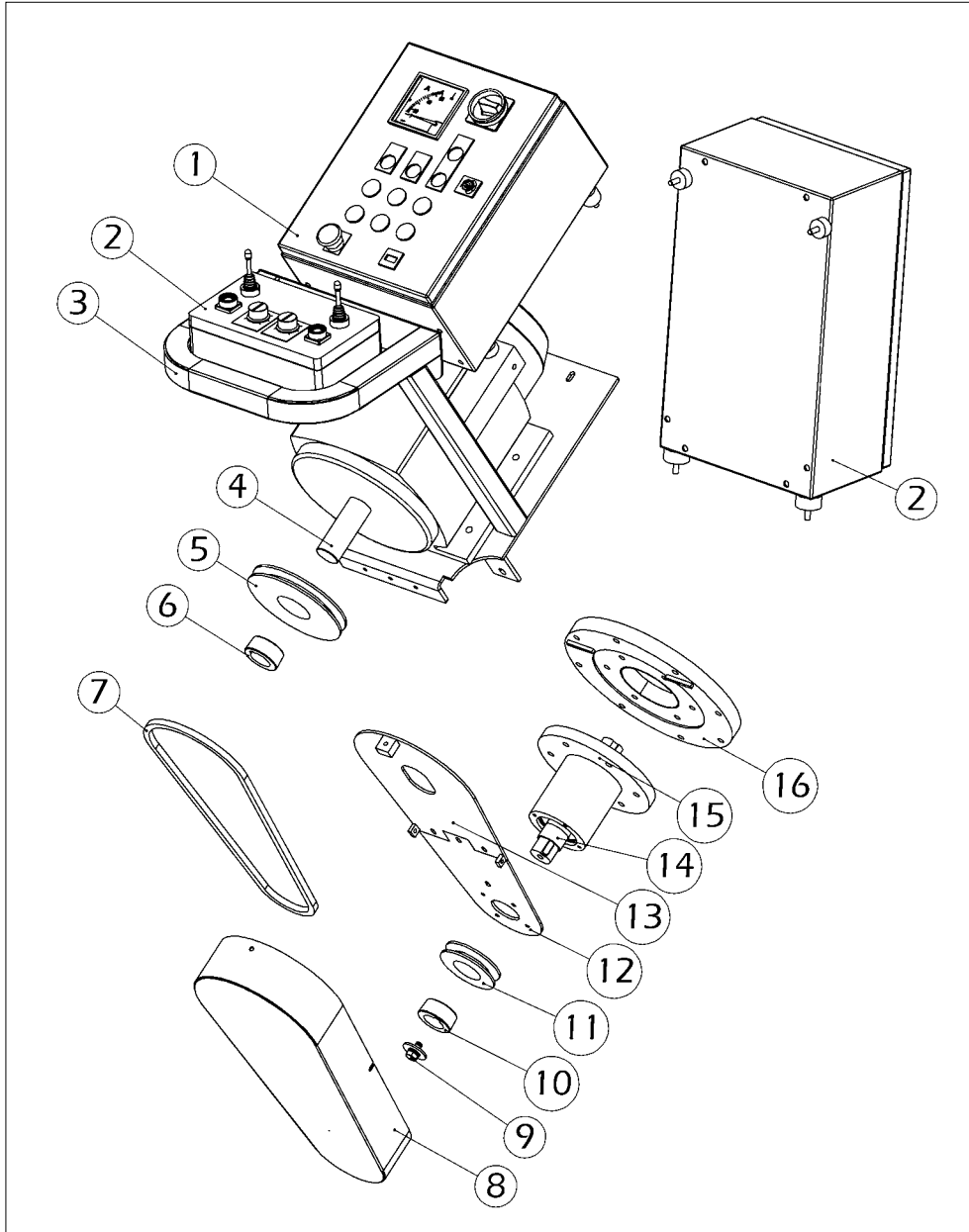

Fig. 10.5

Spare parts

Drive system

Item	Part no.	Description	Qty.
1	500-3011-E	Drive motor	2
2	500-1125-E	Drive motor shaft	2
3	222-2810-VH	Drive motor sprocket	2
4	350-9129-E	Drive motor plate outer left	1
5	350-9131-E	Drive motor plate inner left	1
6	350-9130-E	Drive motor plate outer right	1
7	350-9132-E	Drive motor plate inner right	1
8	350-2185-E	Drive wheel	2
9	500-1135-E	Bearing flange drive wheel shaft	4
10	222-2331-E	Drive wheel bearing	4
11	500-1130-E	Drive wheel shaft	2
12	222-2525-VH	Drive wheel sprocket	2
13	222-2285-V	Taperlock bush	2
14	350-2213-E	Drive motor chain	2
15	350-9105-E	Rear wheel drive chain guard	2

Spare parts

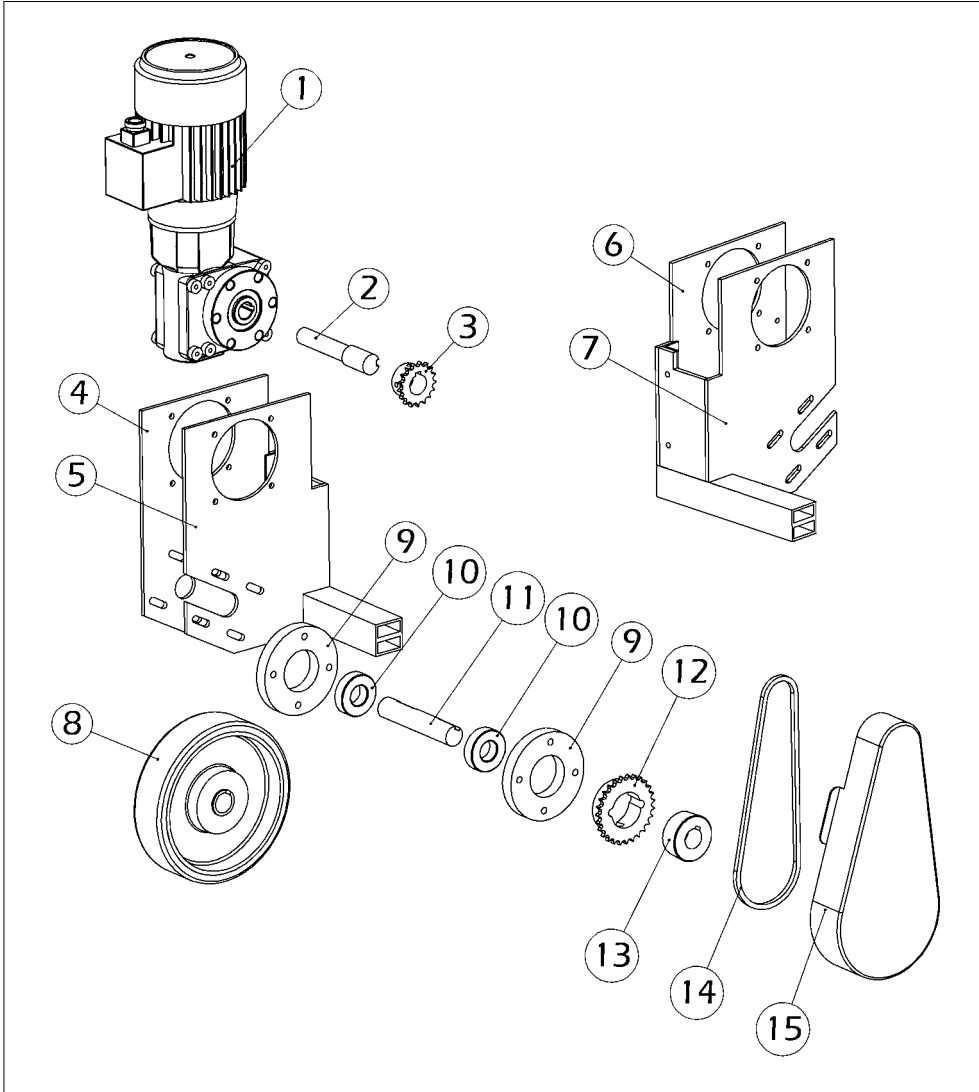

Fig. 10.6